

Please check the examination details below before entering your candidate information

Candidate surname

Other names

Centre Number

Candidate Number

**Pearson Edexcel International Advanced Level**

**Tuesday 7 May 2024**

Morning (Time: 1 hour 30 minutes)

Paper  
reference

**WBI11/01**

**Biology**

**Advanced Subsidiary**

**UNIT 1: Molecules, Diet, Transport and Health**

**You must have:**

Scientific calculator, ruler, HB pencil

Total Marks

### Instructions

- Use **black** ink or ball-point pen.
- **Fill in the boxes** at the top of this page with your name, centre number and candidate number.
- Answer **all** questions.
- Answer the questions in the spaces provided – *there may be more space than you need.*
- Calculators may be used.
- You must **show all your working out** with **your answer clearly identified** at the **end of your solution**.

### Information

- The total mark for this paper is 80.
- The marks for **each** question are shown in brackets – *use this as a guide as to how much time to spend on each question.*
- In questions marked with an **asterisk** (\*), marks will be awarded for your ability to structure your answer logically, showing how the points you make are related or follow on from each other where appropriate.

### Advice

- Read each question carefully before you start to answer it.
- Try to answer every question.
- Check your answers if you have time at the end.

Turn over ►

P75771A

©2024 Pearson Education Ltd.  
F:1/1/1/1/1



Pearson

Answer ALL questions.

Write your answers in the spaces provided.

Some questions must be answered with a cross in a box ☒. If you change your mind about an answer, put a line through the box ☒ and then mark your new answer with a cross ☒.

1 Enzymes are biological catalysts.

(a) Enzyme molecules are formed from chains of amino acids joined together.

Which pair of elements is found in all amino acids?

(1)

- A carbon and oxygen
- B carbon and sulfur
- C nitrogen and magnesium
- D oxygen and magnesium

(b) Which row of the table describes how two amino acids are joined together in an enzyme molecule?

(1)

	Name of bond	Reaction that forms the bond
<input type="checkbox"/> A	ester	condensation
<input type="checkbox"/> B	ester	hydrolysis
<input type="checkbox"/> C	peptide	condensation
<input type="checkbox"/> D	peptide	hydrolysis

DO NOT WRITE IN THIS AREA

DO NOT WRITE IN THIS AREA

DO NOT WRITE IN THIS AREA



(c) Describe how a chain of amino acids can form an enzyme molecule.

(3)

DO NOT WRITE IN THIS AREA

DO NOT WRITE IN THIS AREA

DO NOT WRITE IN THIS AREA

DO NOT WRITE IN THIS AREA

DO NOT WRITE IN THIS AREA

DO NOT WRITE IN THIS AREA

DO NOT WRITE IN THIS AREA

DO NOT WRITE IN THIS AREA

DO NOT WRITE IN THIS AREA

DO NOT WRITE IN THIS AREA

DO NOT WRITE IN THIS AREA

DO NOT WRITE IN THIS AREA

DO NOT WRITE IN THIS AREA

DO NOT WRITE IN THIS AREA

DO NOT WRITE IN THIS AREA

DO NOT WRITE IN THIS AREA

DO NOT WRITE IN THIS AREA

DO NOT WRITE IN THIS AREA

DO NOT WRITE IN THIS AREA

DO NOT WRITE IN THIS AREA

DO NOT WRITE IN THIS AREA

DO NOT WRITE IN THIS AREA

**(Total for Question 1 = 5 marks)**



2 Errors in DNA replication can give rise to mutations.

(a) The diagram shows part of a DNA molecule.

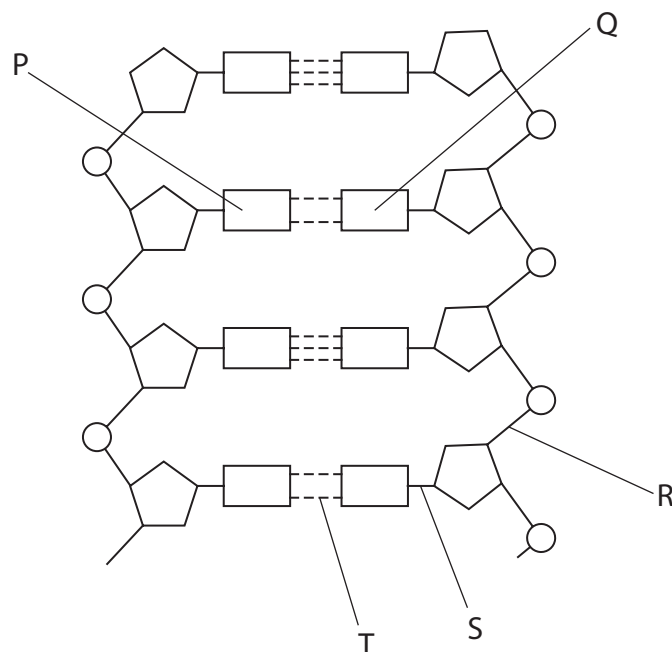

(i) The base labelled **Q** is thymine.

Which is the base labelled **P**?

(1)

- A** adenine
- B** cytosine
- C** guanine
- D** uracil

(ii) Which row of the table identifies the bonds labelled **R**, **S** and **T**?

(1)

	<b>R</b>	<b>S</b>	<b>T</b>
<input type="checkbox"/> <b>A</b>	covalent	phosphodiester	hydrogen
<input type="checkbox"/> <b>B</b>	hydrogen	covalent	phosphodiester
<input type="checkbox"/> <b>C</b>	hydrogen	phosphodiester	covalent
<input type="checkbox"/> <b>D</b>	phosphodiester	covalent	hydrogen



DO NOT WRITE IN THIS AREA

DO NOT WRITE IN THIS AREA

DO NOT WRITE IN THIS AREA

(b) Name **two** types of gene mutation.

(1)

1 .....

2 .....

(c) The graph shows the estimated mutation rate in four groups of primates.

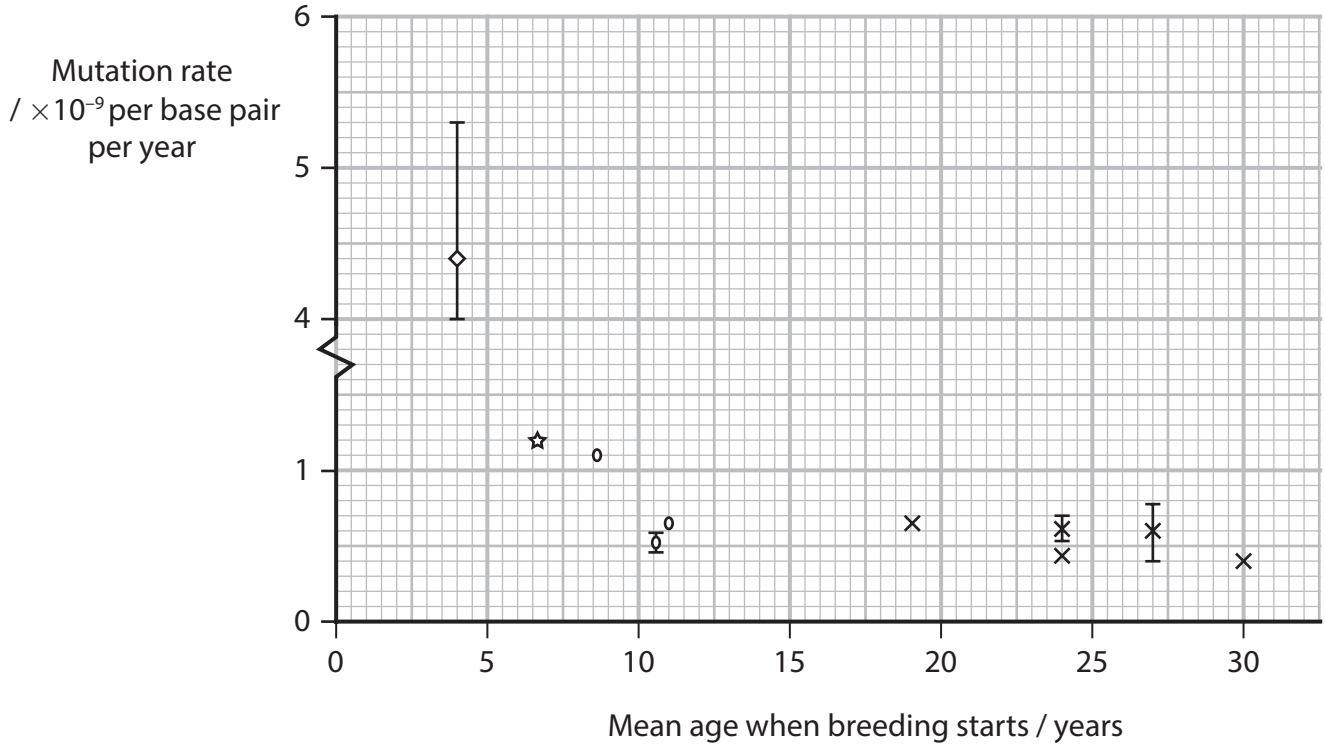

Key			
◇	prosimians	☆	new world monkeys
○	old world monkeys	×	apes

Describe **two** conclusions that can be made about the mutation rate in these four groups of primates.

(2)

1 .....

.....

.....

.....

2 .....

.....

.....

.....

(Total for Question 2 = 5 marks)



P 7 5 7 7 1 A 0 5 2 8

**3** The process of protein synthesis involves RNA polymerase, start and stop codons and ribosomes.

(a) Describe the role of RNA polymerase in protein synthesis.

(2)

.....

.....

.....

.....

.....

.....

.....

(b) Compare and contrast the structure of the start and stop codons and how they work.

(3)

.....

.....

.....

.....

.....

.....

.....

.....

.....

.....

.....



(c) Describe the roles of the ribosomes in protein synthesis.

(2)

.....

.....

.....

.....

.....

.....

**(Total for Question 3 = 7 marks)**

DO NOT WRITE IN THIS AREA

DO NOT WRITE IN THIS AREA

DO NOT WRITE IN THIS AREA



DO NOT WRITE IN THIS AREA

DO NOT WRITE IN THIS AREA

DO NOT WRITE IN THIS AREA

**BLANK PAGE**





4 Many animals have a heart and circulation.

(a) The diagram shows a human heart and its major blood vessels, labelled P, Q, R and S.

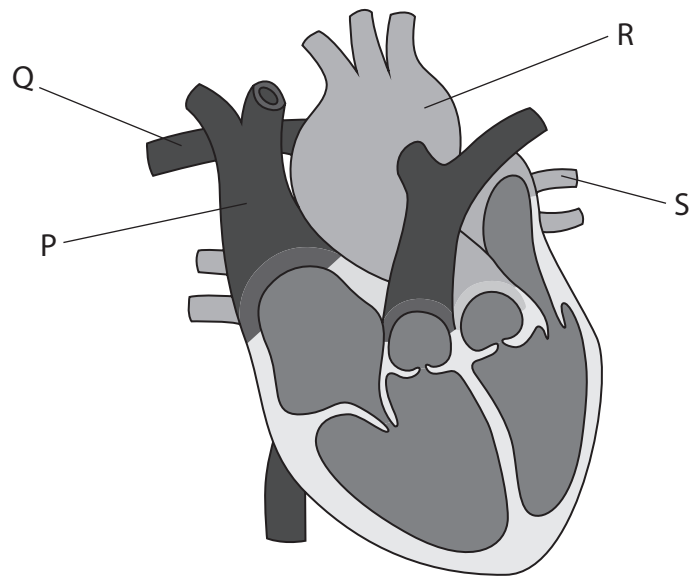

(i) Which pair of blood vessels transports blood to and from the lungs?

(1)

- A P and Q
- B Q and S
- C R and P
- D S and R

(ii) Which blood vessels have valves along their length?

(1)

- A P
- B P and R
- C Q
- D Q and R

(iii) Which blood vessel does the coronary artery branch from?

(1)

- A P
- B Q
- C R
- D S



(b) Capillaries enable the movement of molecules between the blood and cells.

The distance the molecules diffuse between the blood and cells affects the rate of diffusion. This is the diffusion distance.

(i) Name **two** other factors that affect the rate of diffusion.

(1)

1 .....

2 .....

(ii) Name the law of diffusion that can be used to calculate the rate of diffusion.

(1)

(c) The table shows the time taken for a molecule to diffuse over different diffusion distances.

Diffusion distance	Diffusion distance / $\mu\text{m}$	Time taken to diffuse the distance	Time taken to diffuse the distance / milliseconds
1 $\mu\text{m}$	1	0.5 milliseconds	0.5
10 $\mu\text{m}$	10	50.0 milliseconds	50.0
100 $\mu\text{m}$	100	5.0 seconds	
1 mm		8.3 minutes	

(i) Complete the table to show the missing values.

(2)



- (ii) Explain why it is important for body cells to be close to capillaries to meet the demands of respiration.

Use the information in the question and the table to support your answer.

(3)

.....

.....

.....

.....

.....

.....

.....

.....

.....

.....

.....

.....

**(Total for Question 4 = 10 marks)**

DO NOT WRITE IN THIS AREA

DO NOT WRITE IN THIS AREA

DO NOT WRITE IN THIS AREA



5 Haemophilia is a group of rare conditions that affects the ability of the blood to clot. These conditions are caused by mutations in the genes coding for factors involved in the blood clotting process.

(a) Haemophilia is inherited in a similar way to red-green colour blindness and most people who have it are male.

Explain why most people who have haemophilia are male.

(4)

.....

.....

.....

.....

.....

.....

.....

.....

.....

.....

.....

.....

.....

.....

.....

.....

.....

.....

.....

.....

.....

.....

.....

(b) Two types of haemophilia are haemophilia A and haemophilia B.

In 2021, there were  $7.87 \times 10^9$  people in the world.

There were 185 218 people with haemophilia A and 37 998 people with haemophilia B.

(i) Calculate the ratio of people with haemophilia A to those with haemophilia B. Give your answer to **two** significant figures.

(2)

Ratio ..... : 1



(ii) Which is the percentage of the world population who had haemophilia A, in 2021? (1)

- A  $2.35 \times 10^5$
- B  $2.35 \times 10^3$
- C  $2.35 \times 10^{-3}$
- D  $2.35 \times 10^{-5}$

(iii) The number of people with haemophilia is only an estimate.  
Give **one** reason why this is only an estimate. (1)

.....

.....

.....

(c) In haemophilia, activation of the blood clotting pathway results in less thrombin being produced than in healthy individuals.  
Explain how reduced thrombin will affect blood clotting. (3)

.....

.....

.....

.....

.....

.....

.....

.....

.....

.....

.....

(Total for Question 5 = 11 marks)



6 Glucose is an example of a monosaccharide.

Monosaccharides join together to form disaccharides, oligosaccharides and polysaccharides.

Oligosaccharides contain from three to ten monosaccharides.

(a) The diagram shows two glucose molecules.

Complete the diagram to show how these two molecules join by a glycosidic bond to form **two** products.

(3)

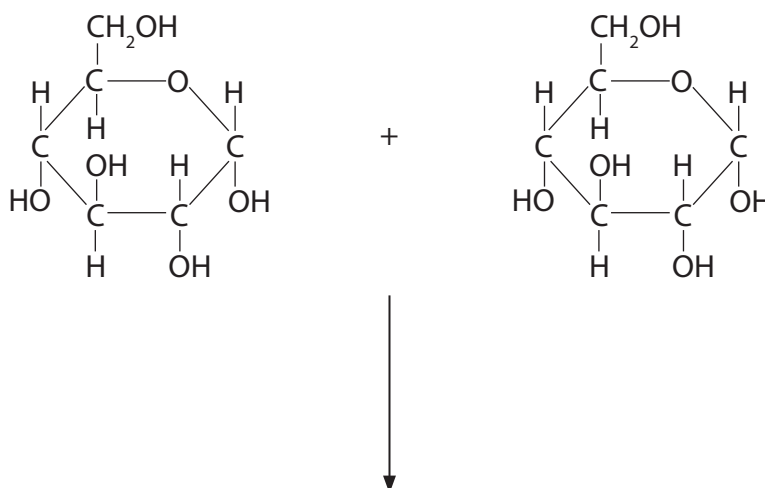

DO NOT WRITE IN THIS AREA

DO NOT WRITE IN THIS AREA

DO NOT WRITE IN THIS AREA



(b) Starch is a polysaccharide composed of amylose and amylopectin.

Digestion of starch begins in the mouth by an enzyme called amylase.

This amylase can break only 1–4 glycosidic bonds.

Only disaccharides and oligosaccharides are produced during this reaction.

(i) The diagram shows part of an amylopectin molecule.

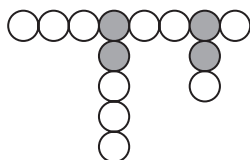

**Key**

○ glucose molecule joined by 1–4 glycosidic bonds

● glucose molecule joined by 1–4 and 1–6 glycosidic bonds

Draw **one** disaccharide and **two** different oligosaccharides that could be produced following the digestion of this part of amylopectin by this amylase.

(2)

(ii) Explain why this amylase is able to break only 1–4 glycosidic bonds.

(2)

.....

.....

.....

.....

.....

.....

.....



(c) The digestion of carbohydrates is completed in the small intestine.

Glucose is then absorbed into the bloodstream.

(i) Suggest how disaccharides and oligosaccharides are broken down in the small intestine.

Give reasons for your answer.

(3)

.....

.....

.....

.....

.....

.....

.....

.....

.....

.....

.....

(ii) The absorption of glucose into the bloodstream requires membrane transport proteins.

Explain why glucose cannot diffuse into the bloodstream.

(2)

.....

.....

.....

.....

.....

.....

.....

.....

.....

.....

**(Total for Question 6 = 12 marks)**





7 Statins are used in the prevention and treatment of cardiovascular disease (CVD).

Red yeast rice (RYR) is a source of food and medicine in Asia. It is produced by the fermentation of rice by yeast.

Red yeast rice contains monacolin K, which is similar to a statin.

(a) The graph shows the production of monacolin K during the fermentation of rice by yeast.

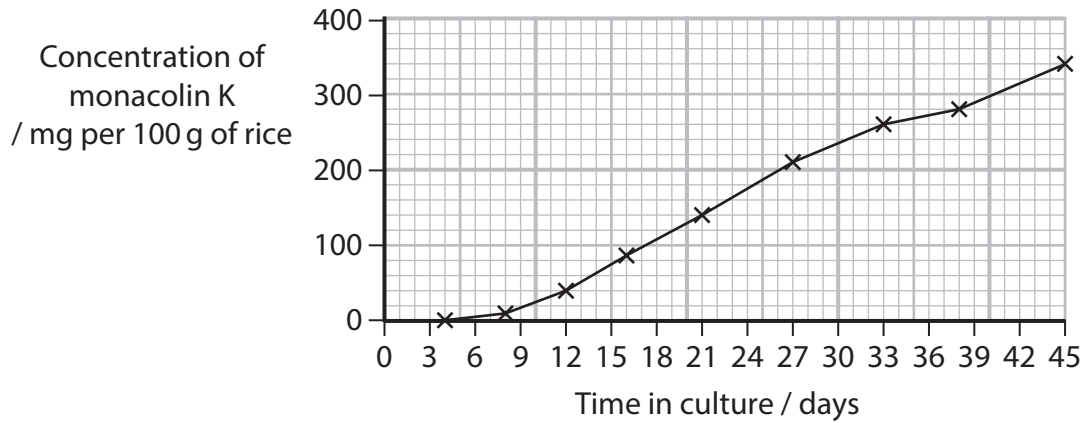

Calculate the mean rate of production of monacolin K in this culture, in the 45-day time period.

Give your answer to **two** decimal places.

(2)

Answer ..... mg per 100 g of rice per day



\*(b) Scientists have studied the effects of RYR on lipid levels.

The table shows the results of four studies on the effects of eating RYR on lipid levels.

Study	Mass of RYR / mg per day	Percentage change in lipid levels (%)		
		Decrease in total cholesterol	Decrease in LDL cholesterol	Change in HDL cholesterol
1	340	16 to 17	21 to 24	Between a decrease of 3 and an increase of 3
2	1200	20	34	Increase of 18
3	2400	13	23	No data
4	1200	13	23	No data
	2400	24	32	No data

Graph 1 shows the effects of eating RYR daily on LDL cholesterol levels.

It also shows the changes in levels of LDL cholesterol when eating RYR was stopped.

The investigation included a control group that did not eat RYR.

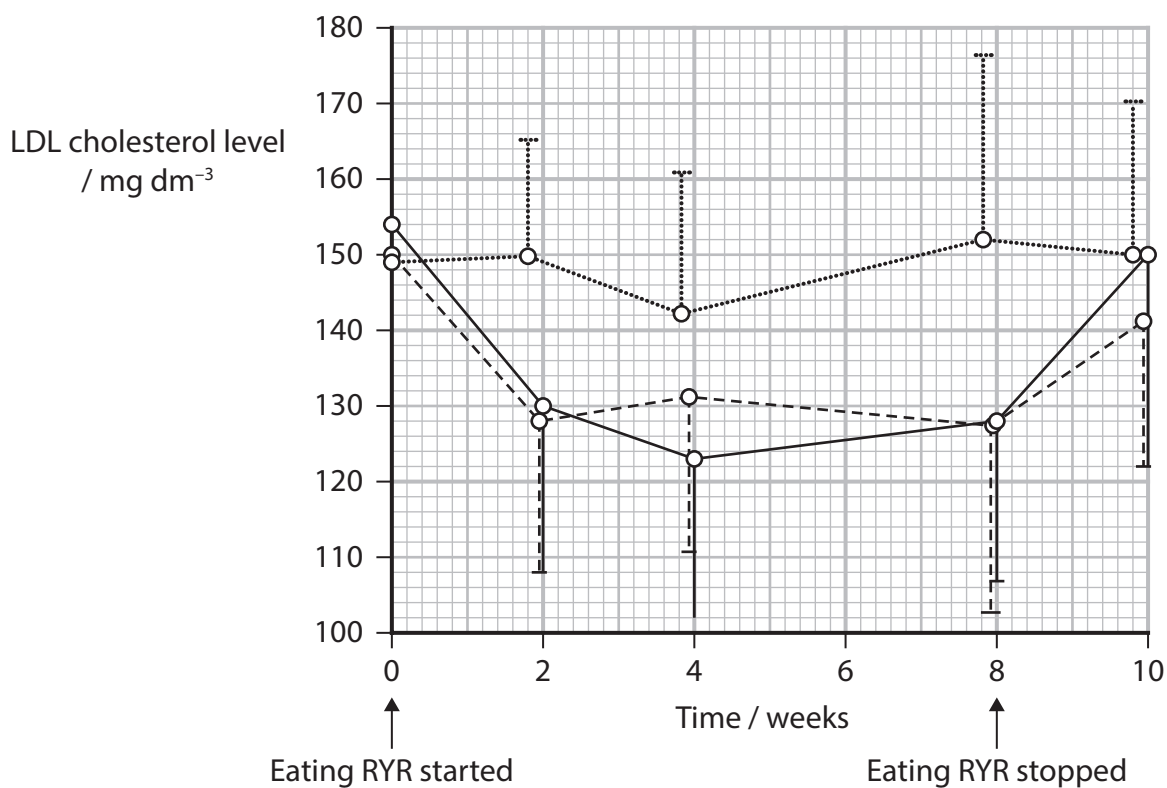

**Key**

..... control (n = 22)    — eating 200 mg RYR (n = 21)    --- eating 100 mg RYR (n = 22)

**Graph 1**



Graph 2 shows the results of another study where the effect of eating RYR on LDL cholesterol levels was compared with a control group.

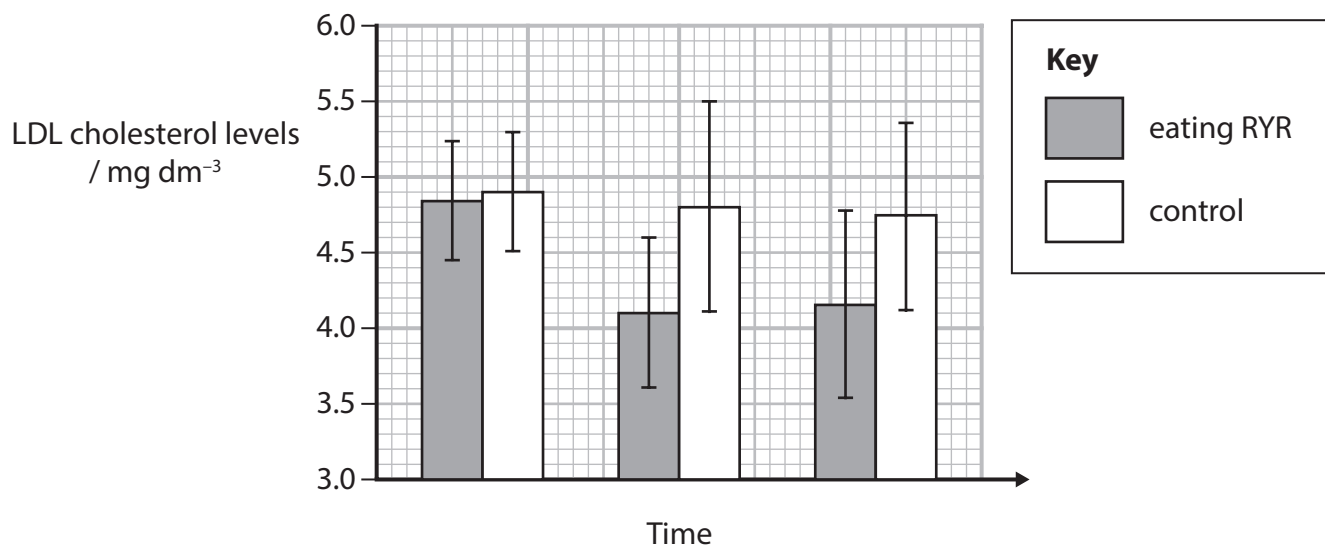

**Graph 2**

Discuss the limitations of using the results of these studies to draw conclusions about the effects of RYR on lipid levels.

(6)

.....

.....

.....

.....

.....

.....

.....

.....

.....

.....

.....

.....

.....

.....

.....

.....

.....

.....

.....

.....

.....

.....

DO NOT WRITE IN THIS AREA

DO NOT WRITE IN THIS AREA

DO NOT WRITE IN THIS AREA



.....

.....

.....

.....

.....

.....

.....

.....

(c) Treatment with statins can have side effects.

(i) Name **two** possible side effects of being treated with statins.

(1)

1 .....

2 .....

(ii) Describe how an investigation could be designed to identify any side effects of treatment with monacolin K.

(4)

.....

.....

.....

.....

.....

.....

.....

.....

.....

.....

.....

.....

.....

.....

.....

.....

.....

.....



(iii) Suggest **two** problems when assessing possible side effects resulting from treatment with monacolin K in an investigation.

(2)

1 .....

.....

.....

2 .....

.....

.....

**(Total for Question 7 = 15 marks)**

DO NOT WRITE IN THIS AREA

DO NOT WRITE IN THIS AREA

DO NOT WRITE IN THIS AREA



P 7 5 7 7 1 A 0 2 1 2 8

- 8 The role of red blood cells is to transport oxygen around the body.

The oxygen-carrying capacity of red blood cells varies from species to species.

The oxygen-carrying capacity depends partly on the size and structure of the red blood cells and their haemoglobin content.

- (a) Describe the structure of a haemoglobin molecule.

(3)

.....

.....

.....

.....

.....

.....

.....

.....

.....

.....

- \*(b) The table shows some information about red blood cells from four species of air-breathing mammals.

The species are listed by decreasing size.

Species of mammal	Mean number of red blood cells per dm <sup>3</sup> of blood	Mean mass of haemoglobin per cell / pg	Mean cell volume / μm <sup>3</sup>	Oxygen-carrying capacity / cm <sup>3</sup> oxygen per dm <sup>3</sup> of blood
Beluga whale	$3.3 \times 10^{12}$	57	134	259
Camel	$1.1 \times 10^{13}$	14	319	211
Man	$5.0 \times 10^{12}$	29	90	196
Goat	$1.6 \times 10^{13}$	7	18	139



Explain the relationships between the sizes of these species of mammal, the characteristics of their red blood cells and their oxygen-carrying capacity.

Use the information in the table to support your answer.

(6)

Handwriting practice area consisting of multiple horizontal dotted lines for writing.

DO NOT WRITE IN THIS AREA

DO NOT WRITE IN THIS AREA

DO NOT WRITE IN THIS AREA



P 7 5 7 7 1 A 0 2 3 2 8

- (c) The graph shows the oxygen dissociation curve for haemoglobin and myoglobin. Myoglobin is present inside muscle cells and acts as an oxygen store.

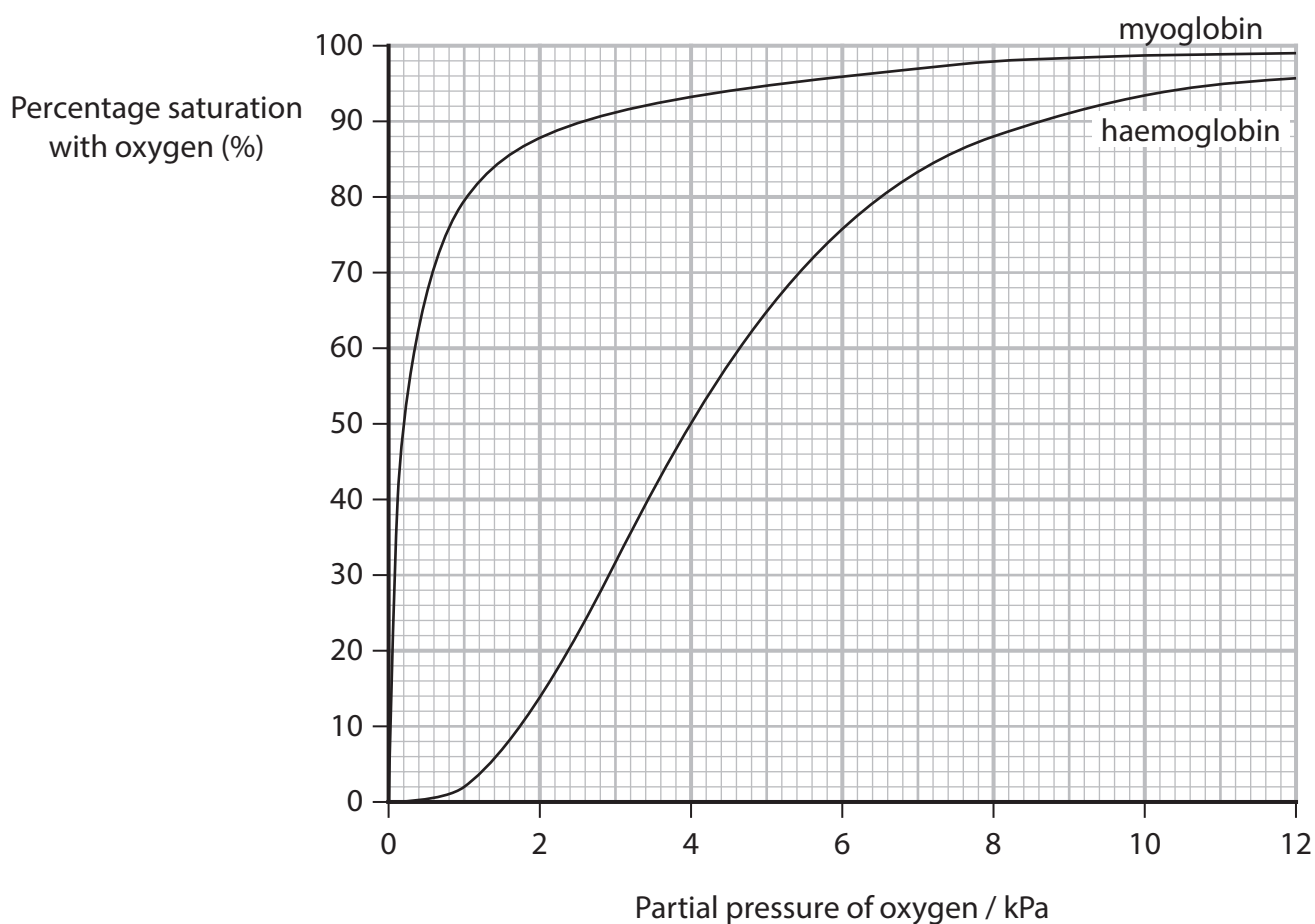

- (i) The decrease in percentage saturation with oxygen of myoglobin from 6 kPa to 4 kPa is 3%.

Calculate the difference between this decrease and the decrease for haemoglobin from 6 kPa to 4 kPa.

(2)

Answer .....%





(ii) Describe the effect of the partial pressure of oxygen on the percentage saturation with oxygen of myoglobin.

Use values from the graph to support your answer.

(2)

.....

.....

.....

.....

.....

.....

(iii) Suggest why the dissociation curve for myoglobin is to the left of the curve for haemoglobin.

(2)

.....

.....

.....

.....

.....

.....

---

**(Total for Question 8 = 15 marks)**

---

**TOTAL FOR PAPER = 80 MARKS**



DO NOT WRITE IN THIS AREA

DO NOT WRITE IN THIS AREA

DO NOT WRITE IN THIS AREA

**BLANK PAGE**



DO NOT WRITE IN THIS AREA

DO NOT WRITE IN THIS AREA

DO NOT WRITE IN THIS AREA

**BLANK PAGE**



P 7 5 7 7 1 A 0 2 7 2 8

DO NOT WRITE IN THIS AREA

DO NOT WRITE IN THIS AREA

DO NOT WRITE IN THIS AREA

**BLANK PAGE**

