

Please check the examination details below before entering your candidate information

Candidate surname

Other names

**Pearson Edexcel**  
**International**  
**Advanced Level**

Centre Number

--	--	--	--	--

Candidate Number

--	--	--	--	--

**Friday 15 May 2020**

Morning (Time: 1 hour 30 minutes)

Paper Reference **WPH12/01**

**Physics**

**International Advanced Subsidiary / Advanced Level**  
**Unit 2: Waves and Electricity**

**You must have:**

Scientific calculator, Ruler

Total Marks

### Instructions

- Use **black** ink or ball-point pen.
- **Fill in the boxes** at the top of this page with your name, centre number and candidate number.
- Answer **all** questions.
- Answer the questions in the spaces provided – *there may be more space than you need.*
- **Show all your working out in calculations and include units where appropriate.**

### Information

- The total mark for this paper is 80.
- The marks for **each** question are shown in brackets – *use this as a guide as to how much time to spend on each question.*
- In questions marked with an **asterisk (\*)**, marks will be awarded for your ability to structure your answer logically showing how the points that you make are related or follow on from each other where appropriate.
- The list of data, formulae and relationships is printed at the end of this booklet.

### Advice

- Read each question carefully before you start to answer it.
- Try to answer every question.
- Check your answers if you have time at the end.

Turn over ►

P62593A

©2020 Pearson Education Ltd.

1/1/1/1



Pearson

## SECTION A

Answer ALL questions.

For questions 1–10 select one answer from A to D and put a cross in the box .  
If you change your mind, put a line through the box  and then  
mark your new answer with a cross .

- 1 Waves can be represented on graphs of displacement against distance and displacement against time.

Which of the following properties can only be determined by combining information from both graphs?

- A amplitude  
 B frequency  
 C speed  
 D wavelength

(Total for Question 1 = 1 mark)

- 2 Two waves from the same source arrive at a point with a path difference of  $\frac{3\lambda}{8}$ , where  $\lambda$  is the wavelength.

Which of the following is the phase difference of the waves at this point?

- A  $34^\circ$   
 B  $68^\circ$   
 C  $135^\circ$   
 D  $270^\circ$

(Total for Question 2 = 1 mark)

DO NOT WRITE IN THIS AREA

DO NOT WRITE IN THIS AREA

DO NOT WRITE IN THIS AREA



- 3 A diffraction grating has 300 lines per mm. When laser light is directed towards the diffraction grating, a diffraction pattern is observed on a screen. The position of a first order maximum on the screen is shown in the diagram.

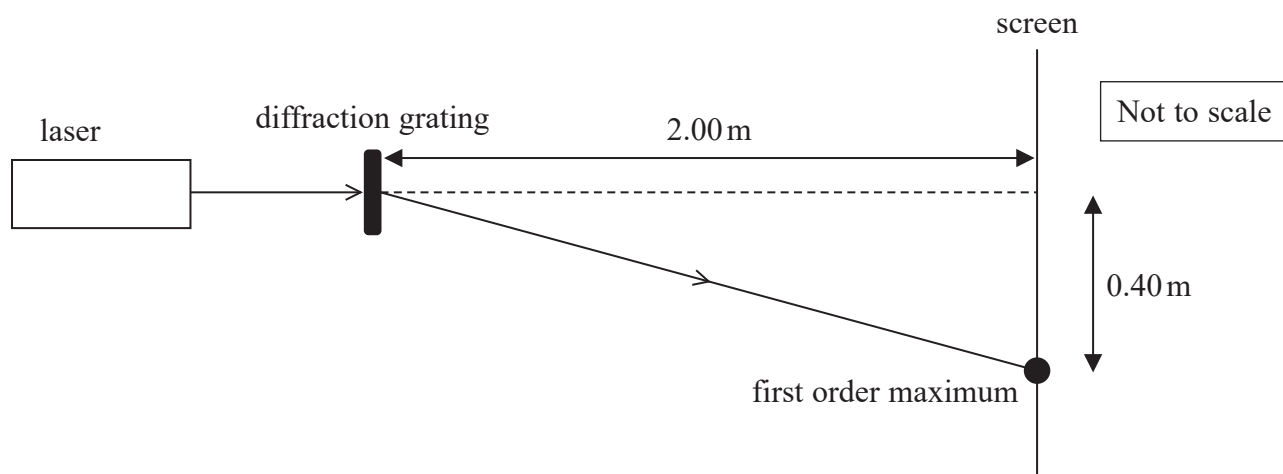

Which of the following calculations should be used to determine the wavelength, in mm, of the laser light used?

- A  $300\sin\theta$  where  $\theta = \sin^{-1}\left(\frac{0.40}{2.00}\right)$
- B  $300\sin\theta$  where  $\theta = \tan^{-1}\left(\frac{0.40}{2.00}\right)$
- C  $\frac{\sin\theta}{300}$  where  $\theta = \sin^{-1}\left(\frac{0.40}{2.00}\right)$
- D  $\frac{\sin\theta}{300}$  where  $\theta = \tan^{-1}\left(\frac{0.40}{2.00}\right)$

(Total for Question 3 = 1 mark)

- 4 Which of the following statements about physical quantities or units is correct?

- A Current is a derived quantity.
- B Power is a derived quantity.
- C The coulomb is a base unit.
- D The volt is a base unit.

(Total for Question 4 = 1 mark)



5 Ultrasound has a number of different uses in medicine.

Which of the following is the main reason why ultrasound is not used to perform scans of the chest and lungs?

- A The air in the lungs causes most of the ultrasound to be reflected back.
- B The duration of the pulses of ultrasound limits the amount of detail that can be seen.
- C The wavelength of the ultrasound is too long.
- D Ultrasound can damage the lungs.

(Total for Question 5 = 1 mark)

6 Which electrical component has the current-potential difference graph shown?

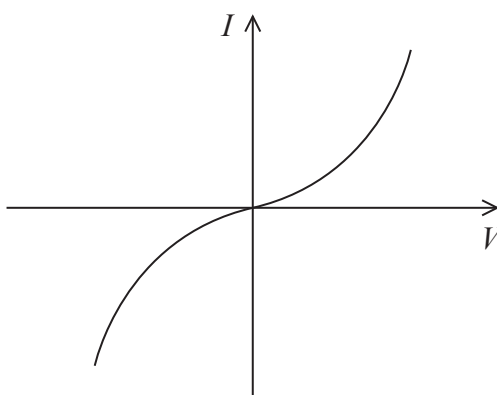

- A diode
- B filament lamp
- C resistor
- D thermistor

(Total for Question 6 = 1 mark)



- 7 A small metal cube, with sides of length  $x$ , is connected in a circuit. The current through the cube, between opposite faces, is  $I$  and the potential difference across the cube is  $V$ .

Which of the following gives the resistivity of the metal?

- A  $\frac{Vx}{I}$
- B  $\frac{V}{Ix}$
- C  $\frac{Ix}{V}$
- D  $\frac{I}{Vx}$

(Total for Question 7 = 1 mark)

- 8 Which of the following statements about waves is correct?

- A Both longitudinal and transverse waves can be polarised.
- B Neither longitudinal nor transverse waves can be polarised.
- C Only longitudinal waves can be polarised.
- D Only transverse waves can be polarised.

(Total for Question 8 = 1 mark)



- 9 Two copper wires are placed in series in a complete circuit. The electrons in the two wires have different values of drift velocity.

Which of the following must be different for the two wires?

- A charge carrier density
- B cross-sectional area
- C current
- D length

(Total for Question 9 = 1 mark)

- 10 The circuit shows a potential divider, including a battery of negligible internal resistance and a light dependent resistor (LDR). The potential difference (p.d.) across the fixed resistor is measured using a voltmeter.

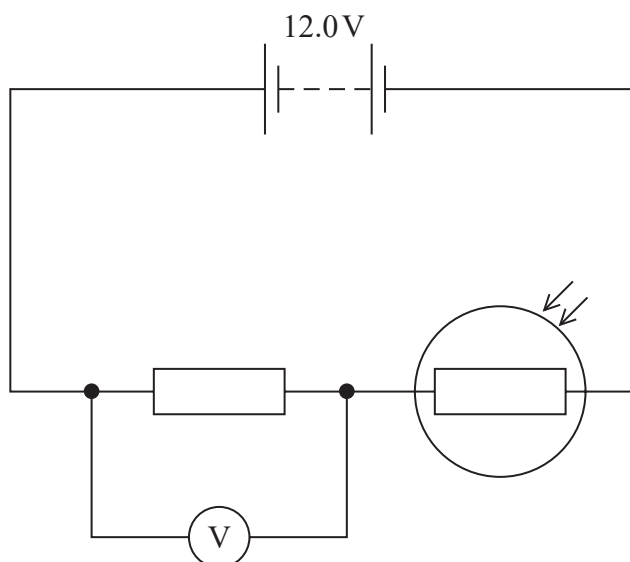

Which of the following statements about this circuit is correct?

- A If the resistance of the LDR halves, the voltmeter reading halves.
- B Increasing the light intensity would decrease the voltmeter reading.
- C Increasing the light intensity would have no effect on the voltmeter reading.
- D The voltmeter reading added to the p.d. across the LDR will always be 12.0 V.

(Total for Question 10 = 1 mark)

**TOTAL FOR SECTION A = 10 MARKS**



DO NOT WRITE IN THIS AREA

DO NOT WRITE IN THIS AREA

DO NOT WRITE IN THIS AREA

**BLANK PAGE**



SECTION B

Answer ALL questions.

- 11 A block of glass is submerged in a container of water. A ray of light travelling in the water is directed towards the glass surface as shown.

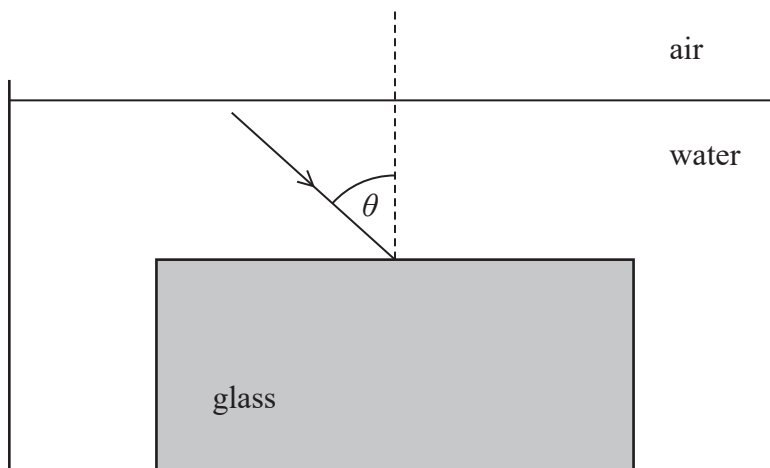

refractive index of water = 1.33  
refractive index of glass = 1.52

- (a) Calculate the angle of refraction within the glass block when  $\theta = 43.0^\circ$ .

(2)

Angle of refraction = .....

- (b) Determine the critical angle for light at a glass-water boundary.

(2)

Critical angle = .....

(Total for Question 11 = 4 marks)

DO NOT WRITE IN THIS AREA

DO NOT WRITE IN THIS AREA

DO NOT WRITE IN THIS AREA





12 A student is given the circuit diagram shown.

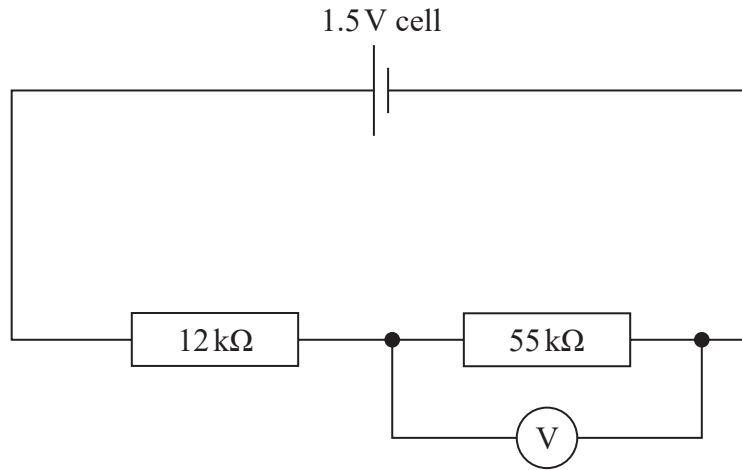

(a) Calculate a value for the voltmeter reading.

(2)

Voltmeter reading = .....

(b) The student sets up the circuit and observes that the reading on the voltmeter is lower than the value calculated in (a).

Explain two reasons for the lower voltmeter reading.

(4)

(Total for Question 12 = 6 marks)



13 Active Noise Reduction (ANR) is a system used to reduce unwanted noise. In ANR a second sound wave is produced that cancels the first. ANR is used in aircraft to reduce the noise heard from the engine.

- (a) On a particular flight, the noise from the engine has a frequency of 0.85 kHz. The graph shows a possible second wave.

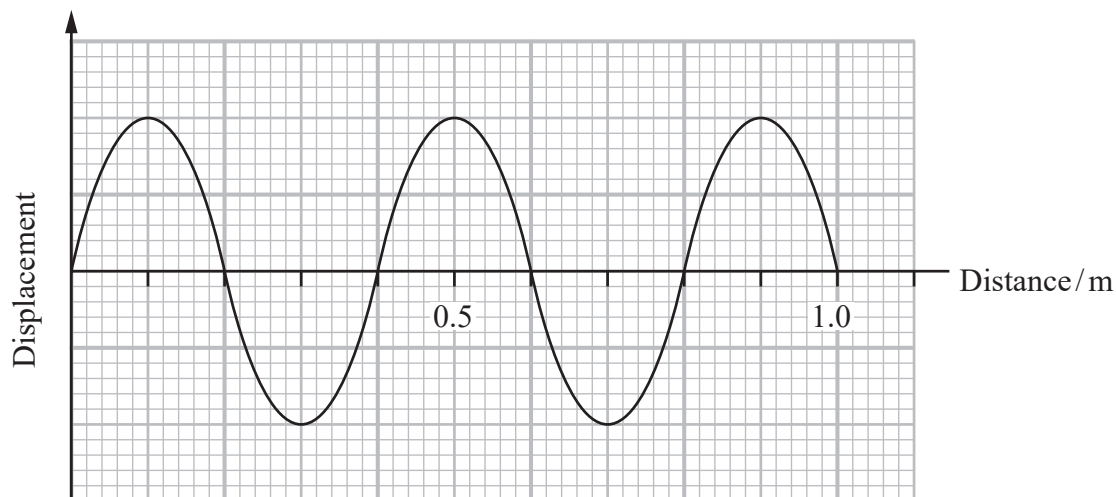

Determine whether this wave could be suitable to cancel the noise from the engine.

speed of sound in air =  $340 \text{ m s}^{-1}$

(3)



\*(b) For a particular passenger in an aircraft, the noise from the engine travels as a wave towards the passenger from the front. An ANR system creates a second sound wave that is directed towards the passenger from the side, as shown.

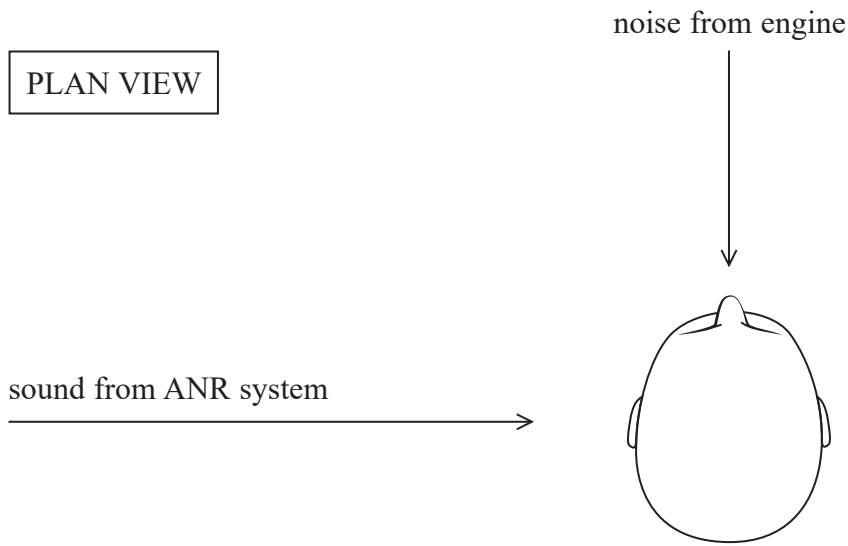

Explain how this can lead to the sound being cancelled for one ear but louder for the other ear.

(6)

.....

.....

.....

.....

.....

.....

.....

.....

.....

.....

.....

.....

.....

.....

.....

.....

.....

.....

.....

.....

.....

.....

.....

(Total for Question 13 = 9 marks)



14 The work functions of four metals are shown in the table.

Metal	Work function / J
potassium	$3.62 \times 10^{-19}$
magnesium	$5.89 \times 10^{-19}$
tungsten	$7.18 \times 10^{-19}$
iron	$7.41 \times 10^{-19}$

(a) State what is meant by work function.

(1)

(b) When light with a frequency of  $6.32 \times 10^{15}$  Hz is incident on a metal, photoelectrons are released with a maximum kinetic energy of  $3.60 \times 10^{-18}$  J.

Determine which of the four metals the light is incident on.

(3)



(c) Ultraviolet radiation is incident on a potassium plate. If the radiation behaved as a wave, there would be a time delay before electrons were emitted from the plate.

- (i) Calculate the time taken for a potassium atom to absorb enough energy to release an electron.

intensity of ultraviolet radiation =  $38.0 \text{ mW m}^{-2}$

area over which a potassium atom absorbs energy =  $8.10 \times 10^{-20} \text{ m}^2$

(3)

Time taken = .....

- (ii) In practice, electrons are emitted from the plate as soon as the ultraviolet radiation is incident on the plate.

Explain how this provides evidence for the particle nature of electromagnetic radiation.

(2)

**(Total for Question 14 = 9 marks)**



- 15 Niels Bohr developed an early model of the atom where electrons could only exist in fixed orbits around a nucleus.

When an atom is ionised, an electron moves from its orbit around the nucleus to be free of the atom. Bohr derived an expression for the ionisation energy  $E$ , in joules, for a hydrogen atom:

$$\left(\frac{e^2}{kh}\right)^2 \times \frac{m}{8}$$

where

$m$  = mass of electron

$e$  = charge of electron

$k = 8.85 \times 10^{-12} \text{ C V}^{-1} \text{ m}^{-1}$

$h$  = Planck constant

- (a) Calculate  $E$  for a hydrogen atom, in eV.

(3)

$E = \dots\dots\dots$  eV



- (b) The Bohr model can also be used to predict an approximate radius for an atom. The equation for the radius  $r$  of the hydrogen atom is:

$$r = \frac{h^2 k}{\pi m e^2}$$

where

$m$  = mass of electron

A student suggests that, for a speed of  $1.4 \times 10^7 \text{ m s}^{-1}$ , neutrons would have a wavelength similar to the radius of a hydrogen atom.

Determine whether the student is correct.

mass of neutron =  $1.67 \times 10^{-27} \text{ kg}$

(5)

(Total for Question 15 = 8 marks)



16 The speed of sound in sea water varies with depth as shown in diagram A.

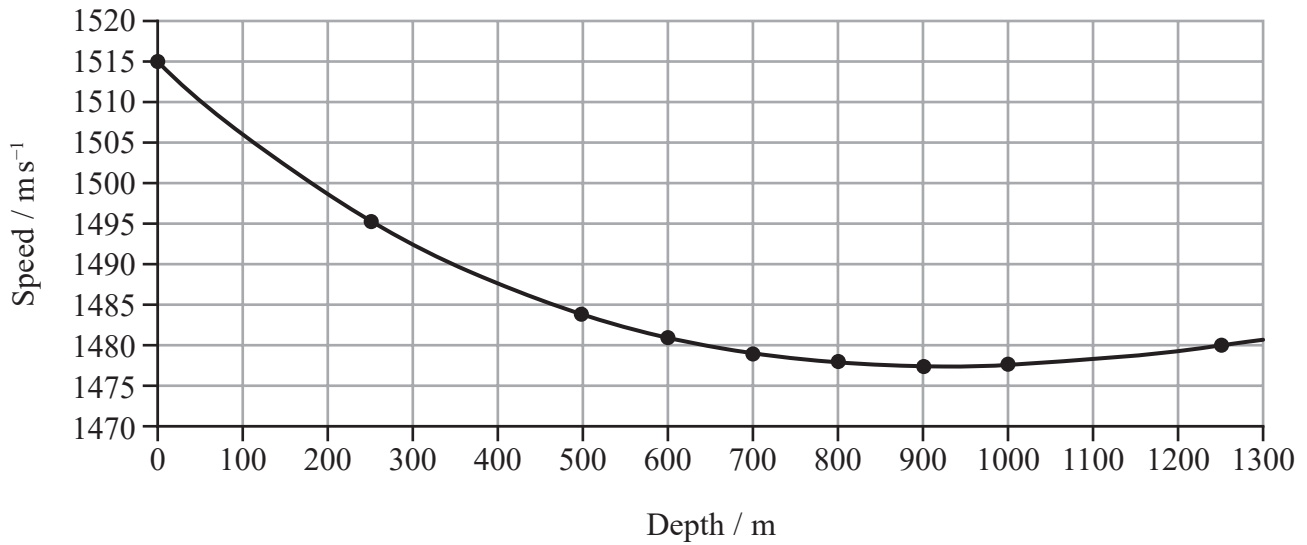

Diagram A

Sound produced at a depth of 900 m initially travels towards the water surface. As the sound approaches a depth of 700 m it changes direction and follows the path shown to the point P in diagram B.

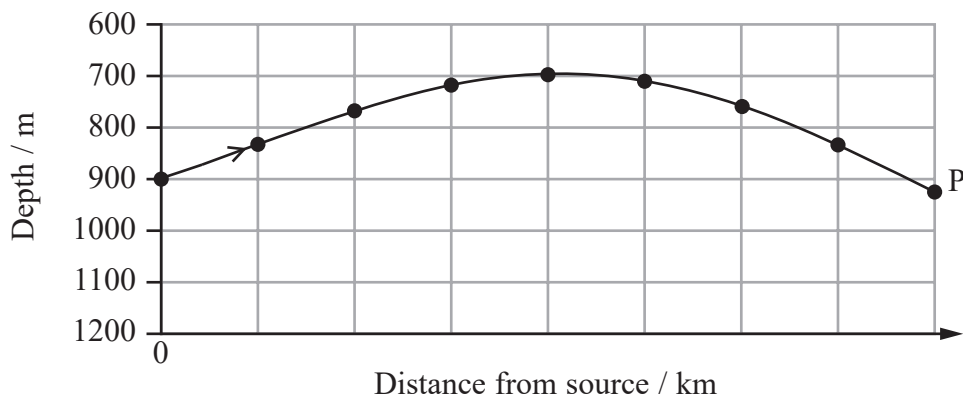

Diagram B

DO NOT WRITE IN THIS AREA

DO NOT WRITE IN THIS AREA

DO NOT WRITE IN THIS AREA





(a) Explain why the sound follows the path shown in diagram B.

Your answer should refer to refraction and diagram A.

(5)

.....

.....

.....

.....

.....

.....

.....

.....

.....

.....

.....

(b) Sound that travels in a straight line from the source to point P takes longer to arrive than sound that travels along the path shown in diagram B.

Suggest why.

(2)

.....

.....

.....

.....

(c) Suggest two factors that might cause the speed of sound to vary with the depth of the sea.

(2)

.....

.....

.....

.....

(Total for Question 16 = 9 marks)



DO NOT WRITE IN THIS AREA

DO NOT WRITE IN THIS AREA

DO NOT WRITE IN THIS AREA

**BLANK PAGE**



- 17 A student investigated how the frequency of vibration of a string varies with the tension in the string. The student connected masses to one end of the string and attached the other end to a vibrator as shown.

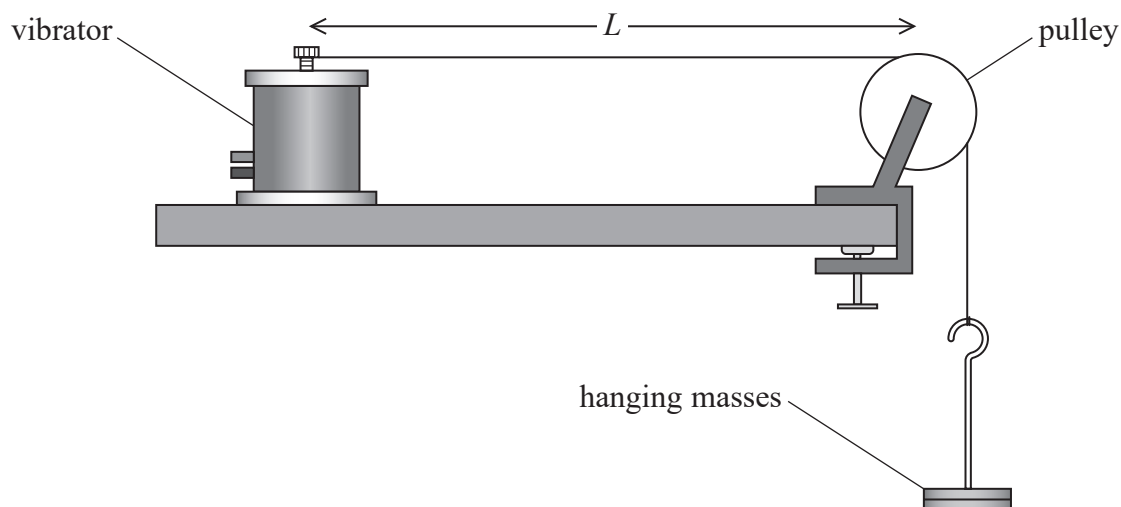

(Source: [http://www.schoolphysics.co.uk/age16-19/Sound/text/Vibrating\\_strings/index.html](http://www.schoolphysics.co.uk/age16-19/Sound/text/Vibrating_strings/index.html))

A signal generator was connected to the vibrator. The signal generator was adjusted until a stationary wave was produced on the string. The stationary wave had nodes at both ends of the vibrating length of the string,  $L$ , and an antinode in the middle.

- (a) Explain how nodes and antinodes are created on a string.

(3)

.....

.....

.....

.....

.....

.....



- (b) The student changed the weight  $W$  applied to the string and adjusted the frequency  $f$  of the signal generator until the same stationary wave was set up on the string.

The student plotted a graph of  $f^2$  against  $W$ .

Explain why the graph was a straight line through the origin.

(5)

.....

.....

.....

.....

.....

.....

.....

.....

.....

.....

.....

.....

.....

.....

.....

.....

.....

.....

.....

.....

.....

.....

.....

- (c) Describe a method that can be used to confirm that the frequency value stated on the signal generator is correct.

(2)

.....

.....

.....

.....

.....



DO NOT WRITE IN THIS AREA

DO NOT WRITE IN THIS AREA

DO NOT WRITE IN THIS AREA

(d) When  $W$  is 80.0 N,  $f$  is 659 Hz.

Calculate the mass per unit length of the string.

length  $L = 0.328$  m

(3)

.....

.....

.....

.....

.....

.....

Mass per unit length = .....

**(Total for Question 17 = 13 marks)**



18 Four identical resistors, A, B, C and D, are placed in a circuit as shown.

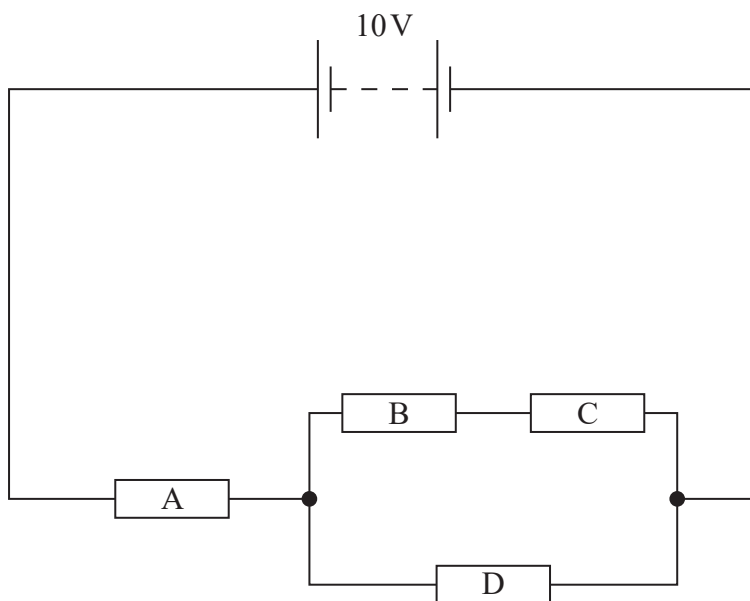

(a) Determine the power dissipated in each of the resistors.

resistance of each resistor =  $2.0\ \Omega$

(6)

.....

.....

.....

.....

.....

.....

.....

.....

.....

.....

.....

.....

.....

.....

.....

.....

.....

.....

.....

.....

.....

.....

DO NOT WRITE IN THIS AREA

DO NOT WRITE IN THIS AREA

DO NOT WRITE IN THIS AREA



(b) Explain, without further calculation, what would happen to the power dissipated by resistor A if resistor D were disconnected from the circuit.

(2)

.....

.....

.....

.....

(c) If the resistors in the circuit used in (a) were replaced with filament lamps, the resistance of each lamp would be different depending on the potential difference across it.

Explain, in terms of particles, why the resistance of a filament lamp increases as the potential difference across the filament increases.

(4)

.....

.....

.....

.....

.....

.....

.....

.....

.....

.....

**(Total for Question 18 = 12 marks)**

---

**TOTAL FOR SECTION B = 70 MARKS**  
**TOTAL FOR PAPER = 80 MARKS**



### List of data, formulae and relationships

Acceleration of free fall	$g = 9.81 \text{ m s}^{-2}$	(close to Earth's surface)
Electron charge	$e = -1.60 \times 10^{-19} \text{ C}$	
Electron mass	$m_e = 9.11 \times 10^{-31} \text{ kg}$	
Electronvolt	$1 \text{ eV} = 1.60 \times 10^{-19} \text{ J}$	
Gravitational field strength	$g = 9.81 \text{ N kg}^{-1}$	(close to Earth's surface)
Planck constant	$h = 6.63 \times 10^{-34} \text{ Js}$	
Speed of light in a vacuum	$c = 3.00 \times 10^8 \text{ m s}^{-1}$	

#### Unit 1

##### Mechanics

Kinematic equations of motion

$$s = \frac{(u + v)t}{2}$$

$$v = u + at$$

$$s = ut + \frac{1}{2}at^2$$

$$v^2 = u^2 + 2as$$

Forces

$$\Sigma F = ma$$

$$g = \frac{F}{m}$$

$$W = mg$$

Momentum

$$p = mv$$

Moment of force

$$\text{moment} = Fx$$

Work and energy

$$\Delta W = F\Delta s$$

$$E_k = \frac{1}{2}mv^2$$

$$\Delta E_{\text{grav}} = mg\Delta h$$

Power

$$P = \frac{E}{t}$$

$$P = \frac{W}{t}$$

Efficiency

$$\text{efficiency} = \frac{\text{useful energy output}}{\text{total energy input}}$$

$$\text{efficiency} = \frac{\text{useful power output}}{\text{total power input}}$$

DO NOT WRITE IN THIS AREA

DO NOT WRITE IN THIS AREA

DO NOT WRITE IN THIS AREA





*Materials*

Density  $\rho = \frac{m}{V}$

Stokes' law  $F = 6\pi\eta rv$

Hooke's law  $\Delta F = k\Delta x$

Elastic strain energy  $\Delta E_{\text{el}} = \frac{1}{2}F\Delta x$

Young modulus  $E = \frac{\sigma}{\varepsilon}$  where

Stress  $\sigma = \frac{F}{A}$

Strain  $\varepsilon = \frac{\Delta x}{x}$



**Unit 2***Waves*

Wave speed  $v = f\lambda$

Speed of a transverse wave on a string  $v = \sqrt{\frac{T}{\mu}}$

Intensity of radiation  $I = \frac{P}{A}$

Refractive index  $n_1 \sin \theta_1 = n_2 \sin \theta_2$

$$n = \frac{c}{v}$$

Critical angle  $\sin C = \frac{1}{n}$

Diffraction grating  $n\lambda = d \sin \theta$

*Electricity*

Potential difference  $V = \frac{W}{Q}$

Resistance  $R = \frac{V}{I}$

Electrical power, energy  $P = VI$

$$P = I^2R$$

$$P = \frac{V^2}{R}$$

$$W = VI t$$

Resistivity  $R = \frac{\rho l}{A}$

Current  $I = \frac{\Delta Q}{\Delta t}$

$$I = nqvA$$

Resistors in series  $R = R_1 + R_2 + R_3$

Resistors in parallel  $\frac{1}{R} = \frac{1}{R_1} + \frac{1}{R_2} + \frac{1}{R_3}$

*Quantum physics*

Photon model  $E = hf$

Einstein's photoelectric equation  $hf = \phi + \frac{1}{2}mv_{\max}^2$

de Broglie wavelength  $\lambda = \frac{h}{p}$



DO NOT WRITE IN THIS AREA

DO NOT WRITE IN THIS AREA

DO NOT WRITE IN THIS AREA

**BLANK PAGE**



P 6 2 5 9 3 A 0 2 7 2 8

DO NOT WRITE IN THIS AREA

DO NOT WRITE IN THIS AREA

DO NOT WRITE IN THIS AREA

**BLANK PAGE**

Every effort has been made to contact copyright holders to obtain their permission for the use of copyright material. Pearson Education Ltd. will, if notified, be happy to rectify any errors or omissions and include any such rectifications in future editions

