

Please check the examination details below before entering your candidate information

Candidate surname

Other names

Centre Number

Candidate Number

--	--	--	--	--

--	--	--	--

## Pearson Edexcel International Advanced Level

Time 1 hour 45 minutes

Paper  
reference

**WPH15/01**

### Physics

International Advanced Level

**UNIT 5: Thermodynamics, Radiation, Oscillations  
and Cosmology**

**You must have:**

Scientific calculator, ruler

Total Marks

### Instructions

- Use **black** ink or ball-point pen.
- If pencil is used for diagrams/sketches/graphs it must be dark (HB or B).
- **Fill in the boxes** at the top of this page with your name, centre number and candidate number.
- Answer **all** questions.
- Answer the questions in the spaces provided  
– *there may be more space than you need.*
- **Show all your working out** in calculations and **include units** where appropriate.

### Information

- The total mark for this paper is 90.
- The marks for **each** question are shown in brackets  
– *use this as a guide as to how much time to spend on each question.*
- In the question marked with an **asterisk (\*)**, marks will be awarded for your ability to structure your answer logically, showing how the points that you make are related or follow on from each other where appropriate.
- The list of data, formulae and relationships is printed at the end of this booklet.

### Advice

- Read each question carefully before you start to answer it.
- Try to answer every question.
- Check your answers if you have time at the end.

Turn over ►

P71891A

©2022 Pearson Education Ltd.

B:1/1/1/



Pearson

## SECTION A

Answer **ALL** the questions in this section.

For questions 1–10, in Section A, select one answer from A to D and put a cross in the box . If you change your mind, put a line through the box  and then mark your new answer with a cross .

- 1 Fission and fusion are both nuclear processes.

Which of the following statements is correct for both processes?

- A No harmful radiation is produced.
- B Nuclear binding energy increases.
- C Very high temperatures are required.
- D The process can occur spontaneously.

(Total for Question 1 = 1 mark)

- 2 The pressure law states that, if certain conditions are met, the pressure exerted by an ideal gas is proportional to the temperature of the gas.

Which of the following conditions is **not** correct?

- A The absolute temperature must be used.
- B The molecules in the gas must be identical.
- C The number of molecules in the gas must stay constant.
- D The volume of the gas must stay constant.

(Total for Question 2 = 1 mark)

- 3 A radioactive source is placed a few centimetres away from a detector.

When a sheet of paper is placed between the source and the detector there is no change in the count rate.

When a lead sheet of thickness 0.5 cm is placed between the source and the detector the count rate is reduced to the background rate.

Which of the following is emitted by the source?

- A alpha and gamma radiation
- B beta and gamma radiation
- C beta radiation only
- D gamma radiation only

(Total for Question 3 = 1 mark)

DO NOT WRITE IN THIS AREA

DO NOT WRITE IN THIS AREA

DO NOT WRITE IN THIS AREA



DO NOT WRITE IN THIS AREA

DO NOT WRITE IN THIS AREA

DO NOT WRITE IN THIS AREA

4 The Hertzsprung-Russell diagram below has an incomplete temperature scale.

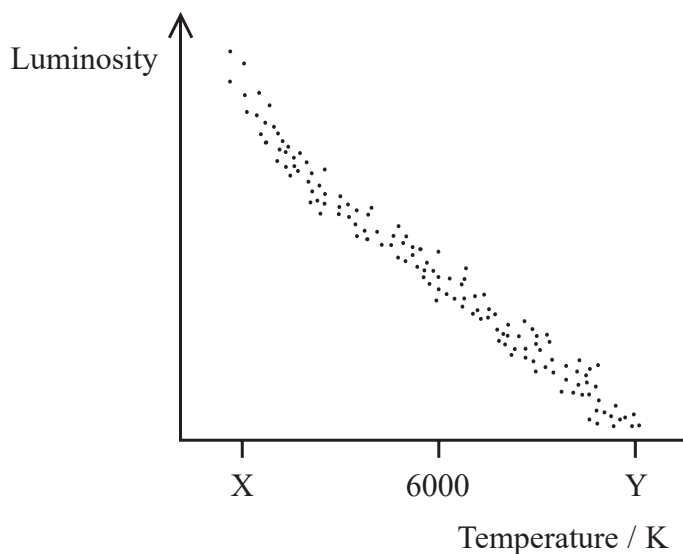

Which row of the table gives possible values for X and Y?

	X	Y
<input type="checkbox"/> A	3000	9000
<input type="checkbox"/> B	3000	12 000
<input type="checkbox"/> C	9000	3000
<input type="checkbox"/> D	12 000	3000

(Total for Question 4 = 1 mark)

5 The radioactive decay of a nucleus is described as a random process.

Which of the following is a reason for this?

- A There are a number of different decay paths.
- B The nucleus will probably decay after one half-life.
- C The nucleus will decay without any external stimulus.
- D There is a fixed probability of the nucleus decaying in the next second.

(Total for Question 5 = 1 mark)



- 6 A graph of red shift against distance in metres was plotted for a range of nearby galaxies. The value of the gradient of the graph was  $5.4 \times 10^{-27}$

Which of the following expressions gives a value for the Hubble constant in  $\text{s}^{-1}$ ?

- A  $5.4 \times 10^{-27}$
- B  $\frac{3 \times 10^8}{5.4 \times 10^{-27}}$
- C  $\frac{1}{3 \times 10^8 \times 5.4 \times 10^{-27}}$
- D  $3 \times 10^8 \times 5.4 \times 10^{-27}$

(Total for Question 6 = 1 mark)

- 7 A space shuttle of mass  $m$  is returning to Earth of mass  $M$ . The space shuttle falls from a height  $R$  above the Earth, where  $R$  is equal to the radius of the Earth.

Which of the following gives the change in gravitational potential energy,  $\Delta E_{\text{grav}}$ , of the space shuttle?

- A  $\Delta E_{\text{grav}} = GMm \left( \frac{1}{2R} - \frac{1}{R} \right)$
- B  $\Delta E_{\text{grav}} = GMm \left( \frac{1}{R} - \frac{1}{2R} \right)$
- C  $\Delta E_{\text{grav}} = \frac{GMm}{R}$
- D  $\Delta E_{\text{grav}} = \frac{GMm}{2R}$

(Total for Question 7 = 1 mark)

- 8 A 'seconds' pendulum has a period of 2 seconds.

Which of the following gives the length of the pendulum in metres?

- A  $\frac{\pi^2}{4 \times 9.81}$
- B  $\frac{4 \times 9.81}{\pi^2}$
- C  $\frac{9.81}{\pi^2}$
- D  $\frac{9.81}{4\pi^2}$

(Total for Question 8 = 1 mark)



9 Canopus and Sirius are two stars.

Radiation from Sirius has 3 times the intensity of radiation from Canopus.  
The distance of Canopus from Earth is 36 times the distance of Sirius from Earth.

Canopus has a luminosity  $L_C$  and Sirius has a luminosity  $L_S$ .

Which of the following is equal to the ratio  $\frac{L_C}{L_S}$ ?

- A  $\frac{1}{3} \times \left(\frac{1}{36}\right)^2$
- B  $3 \times \left(\frac{1}{36}\right)^2$
- C  $\frac{1}{3} \times (36)^2$
- D  $3 \times (36)^2$

(Total for Question 9 = 1 mark)

10 The suspension system of a car was tested by forcing the car into vertical oscillations.

The forcing frequency was gradually increased and corresponding amplitudes of oscillation were measured.

There was a maximum amplitude of oscillation  $A_0$  at a particular frequency  $f_0$ .

Which row of the table shows how  $A_0$  and  $f_0$  change as the damping in the suspension system is reduced?

	$A_0$	$f_0$
<input type="checkbox"/> A	decreases	decreases
<input type="checkbox"/> B	decreases	increases
<input type="checkbox"/> C	increases	decreases
<input type="checkbox"/> D	increases	increases

(Total for Question 10 = 1 mark)

TOTAL FOR SECTION A = 10 MARKS



**SECTION B**

**Answer ALL questions in the spaces provided.**

- 11** A student learns that the energy required to heat water for a bath can be 10 times the energy required to heat water for a shower.

The student uses a shower for 9 minutes. The water comes out of the shower at 38 °C at a flow rate of  $1.8 \times 10^{-5} \text{ m}^3 \text{ s}^{-1}$ .

The student usually fills the bath with 160 kg of water at 32 °C.

Deduce whether the bath uses 10 times more energy than using the shower.

initial temperature of water = 15 °C

density of water =  $1.00 \times 10^3 \text{ kg m}^{-3}$

specific heat capacity of water =  $4.18 \times 10^3 \text{ J kg}^{-1} \text{ K}^{-1}$

.....

.....

.....

.....

.....

.....

.....

.....

.....

.....

.....

.....

.....

.....

.....

.....

.....

.....

.....

.....

.....

.....

.....

**(Total for Question 11 = 5 marks)**

DO NOT WRITE IN THIS AREA

DO NOT WRITE IN THIS AREA

DO NOT WRITE IN THIS AREA



**12** A cylinder contains oxygen gas at a temperature of 25 °C and a pressure of  $1.4 \times 10^7$  Pa.

Calculate the density of the oxygen gas in the cylinder.

mass of an oxygen molecule =  $5.3 \times 10^{-26}$  kg

.....

.....

.....

.....

.....

.....

.....

.....

.....

.....

Density of oxygen gas = .....

**(Total for Question 12 = 5 marks)**



DO NOT WRITE IN THIS AREA

DO NOT WRITE IN THIS AREA

DO NOT WRITE IN THIS AREA

**BLANK PAGE**





DO NOT WRITE IN THIS AREA

DO NOT WRITE IN THIS AREA

DO NOT WRITE IN THIS AREA

**\*13** The average distance between galaxies is many times greater than the size of our galaxy. Astronomers use standard candles to determine the distances to other galaxies.

Describe how astronomers determine the luminosity of a standard candle and can use this to determine the distance to a nearby galaxy.

.....

.....

.....

.....

.....

.....

.....

.....

.....

.....

.....

.....

.....

.....

.....

.....

.....

.....

.....

.....

(Total for Question 13 = 6 marks)



- 14 Due to the gravitational attraction of the Moon, the water level of the oceans rises and falls producing tides.

The Bay of Fundy in Canada has one of the highest tides in the world.

The graph shows how the water level in one location in the Bay of Fundy varied with time over a 7-day period.

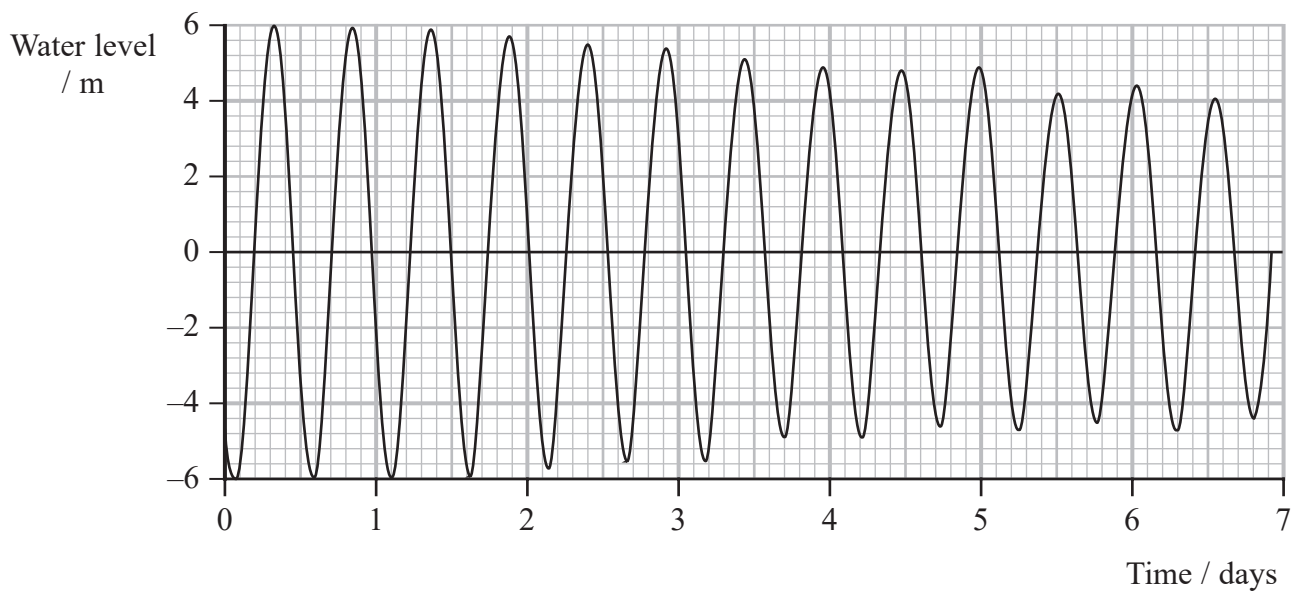

- (a) Determine the period  $T$  of the water level, in hours.

(3)

$T = \dots\dots\dots$  hours



(b) Due to the shape of the Bay of Fundy, the natural period of oscillation of water in the bay is between 12 and 13 hours.

Explain why unusually high tides are observed in the bay.

(3)

.....

.....

.....

.....

.....

.....

.....

.....

**(Total for Question 14 = 6 marks)**

DO NOT WRITE IN THIS AREA

DO NOT WRITE IN THIS AREA

DO NOT WRITE IN THIS AREA



P 7 1 8 9 1 A 0 1 1 3 2

15 GN-z11 is one of the most distant observed galaxies in the universe. A red shift  $z$  of 10.96 has been detected by the Hubble Space Telescope (HST) for radiation from this galaxy.

(a) Radiation with a wavelength of 134 nm was emitted from GN-z11.

Calculate the wavelength  $\lambda_o$  of this radiation when it is detected at the HST.

(2)

$\lambda_o = \dots\dots\dots$

(b) The graph shows how  $z$ , for light emitted from a galaxy, varies with the distance the light has travelled in reaching the Earth.

A light year (ly) is the distance travelled by light in 1 year.

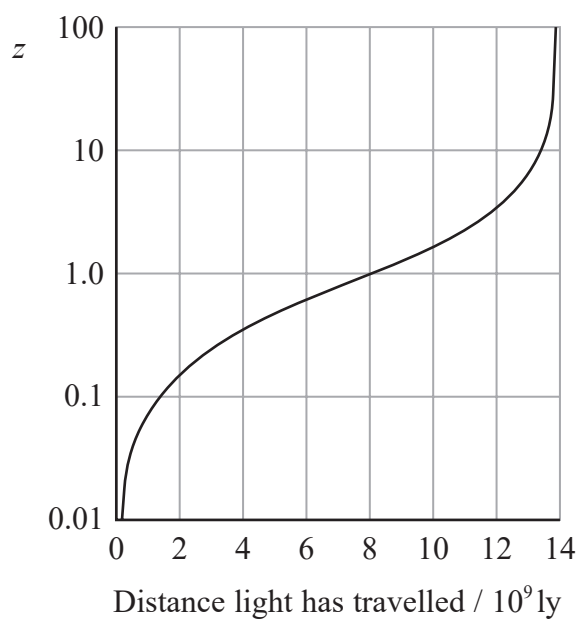

Determine the distance light from GN-z11 has travelled in reaching the Earth, in metres.

$$1 \text{ year} = 3.15 \times 10^7 \text{ s}$$

(3)

.....

.....

.....

Distance the light has travelled = ..... m

- (c) The recently launched James Webb Space Telescope is designed to operate in the infrared region of the spectrum.

Explain why this will be helpful for studying very distant galaxies.

(2)

.....

.....

.....

.....

.....

**(Total for Question 15 = 7 marks)**

DO NOT WRITE IN THIS AREA

DO NOT WRITE IN THIS AREA

DO NOT WRITE IN THIS AREA



16 Gliese-876 is a main sequence star in the constellation Aquarius.

The graph shows how the intensity  $I$  of radiation emitted from Gliese-876 depends upon frequency  $f$ .

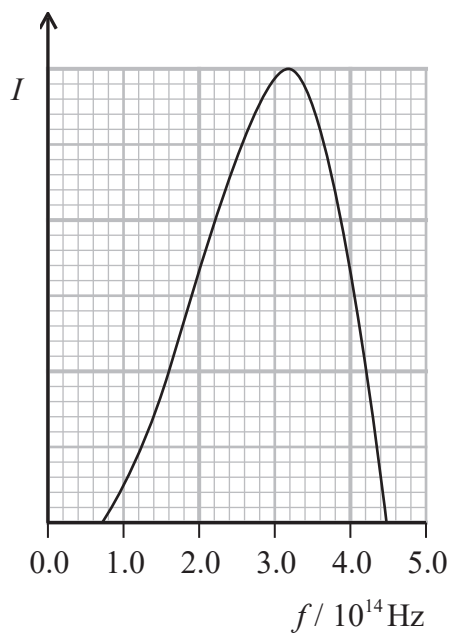

(a) Show that the surface temperature of Gliese-876 is about 3000 K.

(4)

.....

.....

.....

.....

.....

.....

.....

.....

.....

.....



DO NOT WRITE IN THIS AREA

DO NOT WRITE IN THIS AREA

DO NOT WRITE IN THIS AREA

(b) As a red dwarf star, the luminosity of Gliese-876 should be less than 10% of the luminosity of the Sun.

Evaluate whether the surface temperature of Gliese-876 supports this statement.

$$\text{radius of Gliese-876} = 2.62 \times 10^8 \text{ m}$$

$$\text{luminosity of Sun} = 3.83 \times 10^{26} \text{ W}$$

(4)

.....

.....

.....

.....

.....

.....

.....

.....

.....

.....

---

**(Total for Question 16 = 8 marks)**

---



17 The dwarf planet Ceres is the largest object in the asteroid belt.

Ceres has a mass of  $9.38 \times 10^{20}$  kg. Ceres has a circular orbit of radius  $4.14 \times 10^{11}$  m around the Sun.

(a) (i) Show that the gravitational force exerted on Ceres by the Sun is about  $7 \times 10^{17}$  N.

$$\text{mass of Sun} = 1.99 \times 10^{30} \text{ kg}$$

(2)

(ii) Determine the time  $T$ , in years, for Ceres to make one complete orbit about the Sun.

$$1 \text{ year} = 3.15 \times 10^7 \text{ s}$$

(4)

$T = \dots\dots\dots$  years





DO NOT WRITE IN THIS AREA

(b) Mercury is the smallest planet in our solar system. The gravitational field strength  $g_m$  at the surface of Mercury is  $3.7 \text{ N kg}^{-1}$ .

It is claimed that the gravitational field strength at the surface of Ceres is less than 5% of  $g_m$ .

Evaluate whether this claim is accurate.

radius of Ceres = 470 km

(3)

.....

.....

.....

.....

.....

.....

.....

.....

(Total for Question 17 = 9 marks)

.....



18 In 1935 Irène and Frédéric Joliot-Curie were awarded a Nobel Prize for the discovery of artificial radioactivity.

They bombarded an aluminium sheet with alpha particles to produce a radioactive isotope of phosphorus as in the nuclear equation below.



(a) (i) Identify particle X.

(1)

(ii) Calculate the energy released, in joules, in this nuclear reaction.

Particle	Mass / GeV / $c^2$
${}^1\text{X}$	0.9396
${}^4\alpha$	3.7274
${}^{27}\text{Al}$	25.1333
${}^{30}\text{P}$	27.9206

(4)

Energy released = ..... J



DO NOT WRITE IN THIS AREA

(b) Radioactive phosphorus was one of the first artificially produced isotopes to be used in the diagnosis of cancerous tumours.

The isotope  $^{32}\text{P}$  is injected into a person and collects in the tumour. Radiation is detected outside the person's body.  $^{32}\text{P}$  is a positron emitter with a half-life of almost fifteen days.

Explain why  $^{32}\text{P}$  is suitable for this procedure.

(4)

.....

.....

.....

.....

.....

.....

.....

.....

.....

.....

(Total for Question 18 = 9 marks)



19 A can of spray paint needs to be shaken before being used.

The diagram shows a machine designed to shake a can of spray paint.

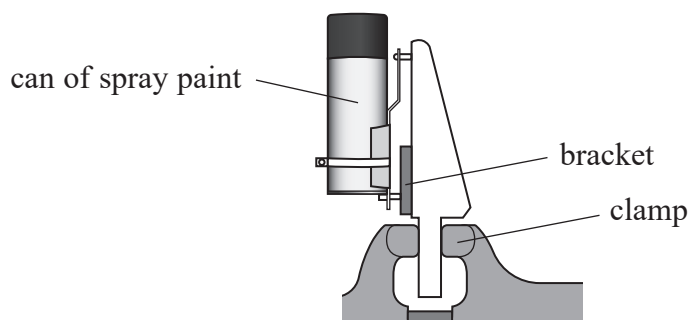

The bracket oscillates vertically with simple harmonic motion.

(a) State the conditions necessary for an object to move with simple harmonic motion.

(2)

.....

.....

.....

.....

(b) When the bracket is oscillating, the distance between the highest and lowest positions of the bracket is 8.0 cm. The bracket completes 270 oscillations per minute.

(i) Sketch a graph on the axes opposite to show how the velocity  $v$  of the bracket depends upon time  $t$ . Your graph should include velocity and time values.

(6)

.....

.....

.....

.....





(ii) Determine the maximum acceleration of the bracket. (2)

.....

.....

.....

Maximum acceleration of bracket = .....

(iii) Suggest why the particles of paint in the can will experience a maximum acceleration that is different from the answer to (ii). (1)

.....

.....

**(Total for Question 19 = 11 marks)**

---

.....

.....

.....

.....

.....



DO NOT WRITE IN THIS AREA

DO NOT WRITE IN THIS AREA

DO NOT WRITE IN THIS AREA

**BLANK PAGE**



20 Caesium-137 is a radioactive isotope produced during the fission of uranium.

(a) State what is meant by fission.

(1)

(b) (i) Caesium-137 decays by emitting beta radiation.

Complete the nuclear equation for the decay of caesium-137.



(2)

(ii) Explain why the emission of an antineutrino in the decay leads to a range of energies for the  $\beta^{-}$  particles.

(2)



(c) Caesium-137 is a major source of radiation from radioactive waste.

(i) A nuclear fission reactor produces about 24 kg of caesium-137 each year.

A website states that 24 kg of caesium-137 has the same activity as 2000 kg of radium-226.

Assess whether this statement is correct.

half-life of caesium-137 = 30.2 years

mass of a caesium atom = 136.9 u

activity of 2000 kg of radium-226 =  $7.33 \times 10^{16}$  Bq

1 year =  $3.15 \times 10^7$  s

(6)





(ii) Caesium-137 may enter plants grown in a contaminated area.

The radiation from 100 g of plant material grown in a contaminated area can have a count rate as high as 500 Bq. A count rate of  $150 \text{ min}^{-1}$  is considered safe.

Determine the time taken for the count rate from 25 g of plant material grown in a contaminated area to fall to a safe level.

(3)

Time taken = .....

**(Total for Question 20 = 14 marks)**

**TOTAL FOR SECTION B = 80 MARKS**

**TOTAL FOR PAPER = 90 MARKS**

DO NOT WRITE IN THIS AREA

DO NOT WRITE IN THIS AREA

DO NOT WRITE IN THIS AREA



### List of data, formulae and relationships

Acceleration of free fall	$g = 9.81 \text{ m s}^{-2}$	(close to Earth's surface)
Boltzmann constant	$k = 1.38 \times 10^{-23} \text{ J K}^{-1}$	
Coulomb's law constant	$k = 1/4\pi\epsilon_0$ $= 8.99 \times 10^9 \text{ N m}^2 \text{ C}^{-2}$	
Electron charge	$e = -1.60 \times 10^{-19} \text{ C}$	
Electron mass	$m_e = 9.11 \times 10^{-31} \text{ kg}$	
Electronvolt	$1 \text{ eV} = 1.60 \times 10^{-19} \text{ J}$	
Gravitational constant	$G = 6.67 \times 10^{-11} \text{ N m}^2 \text{ kg}^{-2}$	
Gravitational field strength	$g = 9.81 \text{ N kg}^{-1}$	(close to Earth's surface)
Permittivity of free space	$\epsilon_0 = 8.85 \times 10^{-12} \text{ F m}^{-1}$	
Planck constant	$h = 6.63 \times 10^{-34} \text{ J s}$	
Proton mass	$m_p = 1.67 \times 10^{-27} \text{ kg}$	
Speed of light in a vacuum	$c = 3.00 \times 10^8 \text{ m s}^{-1}$	
Stefan-Boltzmann constant	$\sigma = 5.67 \times 10^{-8} \text{ W m}^{-2} \text{ K}^{-4}$	
Unified atomic mass unit	$u = 1.66 \times 10^{-27} \text{ kg}$	

### Unit 1

#### Mechanics

Kinematic equations of motion	$s = \frac{(u + v)t}{2}$
	$v = u + at$
	$s = ut + \frac{1}{2}at^2$
	$v^2 = u^2 + 2as$

#### Forces

$$\Sigma F = ma$$

$$g = \frac{F}{m}$$

$$W = mg$$

#### Momentum

$$p = mv$$

#### Moment of force

$$\text{moment} = Fx$$

#### Work and energy

$$\Delta W = F\Delta s$$

$$E_k = \frac{1}{2}mv^2$$

$$\Delta E_{\text{grav}} = mg\Delta h$$

#### Power

$$P = \frac{E}{t}$$

$$P = \frac{W}{t}$$



Efficiency

$$\text{efficiency} = \frac{\text{useful energy output}}{\text{total energy input}}$$

$$\text{efficiency} = \frac{\text{useful power output}}{\text{total power input}}$$

*Materials*

Density

$$\rho = \frac{m}{V}$$

Stokes' law

$$F = 6\pi\eta rv$$

Hooke's law

$$\Delta F = k\Delta x$$

Elastic strain energy

$$\Delta E_{\text{el}} = \frac{1}{2}F\Delta x$$

Young modulus

$$E = \frac{\sigma}{\varepsilon} \text{ where}$$

$$\text{Stress } \sigma = \frac{F}{A}$$

$$\text{Strain } \varepsilon = \frac{\Delta x}{x}$$

DO NOT WRITE IN THIS AREA

DO NOT WRITE IN THIS AREA

DO NOT WRITE IN THIS AREA



**Unit 2***Waves*

Wave speed	$v = f\lambda$
Speed of a transverse wave on a string	$v = \sqrt{\frac{T}{\mu}}$
Intensity of radiation	$I = \frac{P}{A}$
Refractive index	$n_1 \sin \theta_1 = n_2 \sin \theta_2$ $n = \frac{c}{v}$
Critical angle	$\sin C = \frac{1}{n}$
Diffraction grating	$n\lambda = d \sin \theta$

*Electricity*

Potential difference	$V = \frac{W}{Q}$
Resistance	$R = \frac{V}{I}$
Electrical power, energy	$P = VI$ $P = I^2R$ $P = \frac{V^2}{R}$ $W = VI t$
Resistivity	$R = \frac{\rho l}{A}$
Current	$I = \frac{\Delta Q}{\Delta t}$ $I = nqvA$
Resistors in series	$R = R_1 + R_2 + R_3$
Resistors in parallel	$\frac{1}{R} = \frac{1}{R_1} + \frac{1}{R_2} + \frac{1}{R_3}$

*Particle nature of light*

Photon model	$E = hf$
Einstein's photoelectric equation	$hf = \phi + \frac{1}{2}mv_{\max}^2$
de Broglie wavelength	$\lambda = \frac{h}{p}$



## Unit 4

### Further mechanics

Impulse

$$F\Delta t = \Delta p$$

Kinetic energy of a non-relativistic particle

$$E_k = \frac{p^2}{2m}$$

Motion in a circle

$$v = \omega r$$

$$T = \frac{2\pi}{\omega}$$

$$a = \frac{v^2}{r}$$

$$a = r\omega^2$$

Centripetal force

$$F = ma = \frac{mv^2}{r}$$

$$F = mr\omega^2$$

### Electric and magnetic fields

Electric field

$$E = \frac{F}{Q}$$

Coulomb's law

$$F = \frac{Q_1 Q_2}{4\pi\epsilon_0 r^2}$$

$$E = \frac{Q}{4\pi\epsilon_0 r^2}$$

$$E = \frac{V}{d}$$

Electrical potential

$$V = \frac{Q}{4\pi\epsilon_0 r}$$

Capacitance

$$C = \frac{Q}{V}$$

Energy stored in capacitor

$$W = \frac{1}{2} QV$$

$$W = \frac{1}{2} CV^2$$

$$W = \frac{1}{2} \frac{Q^2}{C}$$

Capacitor discharge

$$Q = Q_0 e^{-t/RC}$$



Resistor-capacitor discharge

$$I = I_0 e^{-t/RC}$$

$$V = V_0 e^{-t/RC}$$

$$\ln Q = \ln Q_0 - \frac{t}{RC}$$

$$\ln I = \ln I_0 - \frac{t}{RC}$$

$$\ln V = \ln V_0 - \frac{t}{RC}$$

In a magnetic field

$$F = Bqv \sin \theta$$

$$F = BIl \sin \theta$$

Faraday's and Lenz's laws

$$\mathcal{E} = \frac{-d(N\phi)}{dt}$$

*Nuclear and particle physics*

In a magnetic field

$$r = \frac{p}{BQ}$$

Mass-energy

$$\Delta E = c^2 \Delta m$$

DO NOT WRITE IN THIS AREA

DO NOT WRITE IN THIS AREA

DO NOT WRITE IN THIS AREA



## Unit 5

### Thermodynamics

Heating  $\Delta E = mc\Delta\theta$

$$\Delta E = L\Delta m$$

Ideal gas equation  $pV = NkT$

Molecular kinetic theory  $\frac{1}{2}m\langle c^2 \rangle = \frac{3}{2}kT$

### Nuclear decay

Mass-energy  $\Delta E = c^2\Delta m$

Radioactive decay  $A = \lambda N$

$$\frac{dN}{dt} = -\lambda N$$

$$\lambda = \frac{\ln 2}{t_{1/2}}$$

$$N = N_0 e^{-\lambda t}$$

$$A = A_0 e^{-\lambda t}$$

### Oscillations

Simple harmonic motion  $F = -kx$

$$a = -\omega^2 x$$

$$x = A \cos \omega t$$

$$v = -A\omega \sin \omega t$$

$$a = -A\omega^2 \cos \omega t$$

$$T = \frac{1}{f} = \frac{2\pi}{\omega}$$

$$\omega = 2\pi f$$

Simple harmonic oscillator  $T = 2\pi\sqrt{\frac{m}{k}}$

$$T = 2\pi\sqrt{\frac{l}{g}}$$



*Astrophysics and cosmology*

Gravitational field strength  $g = \frac{F}{m}$

Gravitational force  $F = \frac{Gm_1m_2}{r^2}$

Gravitational field  $g = \frac{Gm}{r^2}$

Gravitational potential  $V_{\text{grav}} = \frac{-Gm}{r}$

Stefan-Boltzmann law  $L = \sigma AT^4$

Wien's law  $\lambda_{\text{max}}T = 2.898 \times 10^{-3} \text{ mK}$

Intensity of radiation  $I = \frac{L}{4\pi d^2}$

Redshift of electromagnetic radiation  $z = \frac{\Delta\lambda}{\lambda} \approx \frac{\Delta f}{f} \approx \frac{v}{c}$

Cosmological expansion  $v = H_0 d$

DO NOT WRITE IN THIS AREA

DO NOT WRITE IN THIS AREA

DO NOT WRITE IN THIS AREA

