

Please check the examination details below before entering your candidate information

Candidate surname

Other names

Centre Number

Candidate Number

Pearson Edexcel International Advanced Level

Monday 20 May 2024

Morning (Time: 1 hour 20 minutes)

Paper
reference

WPH13/01

Physics

International Advanced Subsidiary/Advanced Level

UNIT 3: Practical Skills in Physics I

You must have:

Scientific calculator, ruler

Total Marks

Instructions

- Use **black** ink or ball-point pen.
- If pencil is used for diagrams/sketches/graphs it must be dark (HB or B).
- **Fill in the boxes** at the top of this page with your name, centre number and candidate number.
- Answer **all** questions.
- Answer the questions in the spaces provided
– *there may be more space than you need.*
- **Show all your working out** in calculations and **include units** where appropriate.

Information

- The total mark for this paper is 50.
- The marks for **each** question are shown in brackets
– *use this as a guide as to how much time to spend on each question.*
- The list of data, formulae and relationships is printed at the end of this booklet.

Advice

- Read each question carefully before you start to answer it.
- Try to answer every question.
- Check your answers if you have time at the end.

Turn over ►

P75809A

©2024 Pearson Education Ltd.
F:1/1/



Pearson

Answer ALL questions.

- 1 A student investigated the force needed to break a rubber band. He planned to use the apparatus shown.

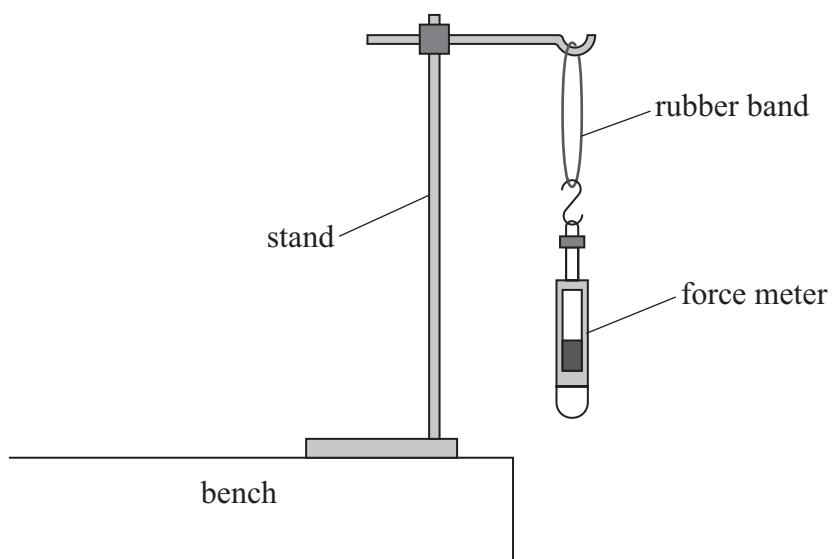

- (a) The student suggested pulling down on the force meter until the rubber band breaks.
- (i) Identify **two** health and safety issues and how they should be dealt with.

(4)

.....

.....

.....

.....

.....

.....

DO NOT WRITE IN THIS AREA

DO NOT WRITE IN THIS AREA

DO NOT WRITE IN THIS AREA



(ii) Describe a method the student could use which would **not** include a force meter.

You should include the use of additional apparatus.

(2)

.....

.....

.....

.....

.....

.....

(b) The student investigated how the breaking force of the rubber bands changed at low temperature.

The student placed five identical rubber bands in a freezer at -10°C .

The student removed one rubber band from the freezer and determined the breaking force. He repeated this for the other rubber bands.

Explain why it is appropriate to repeat the measurements.

(2)

.....

.....

.....

.....

.....

.....

(Total for Question 1 = 8 marks)

DO NOT WRITE IN THIS AREA

DO NOT WRITE IN THIS AREA

DO NOT WRITE IN THIS AREA



2 A student investigated a ball bouncing from a slope, using the apparatus shown.

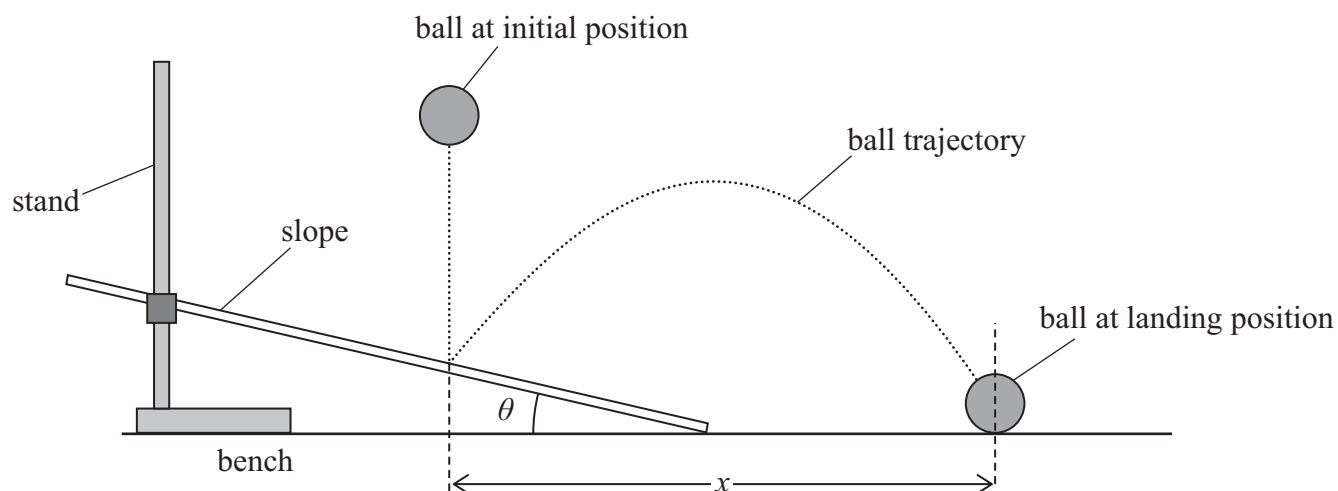

The student used a protractor to measure the angle θ of the slope to the horizontal.

She dropped the ball from the initial position shown. She used a metre rule to measure the distance x .

She varied θ and measured corresponding values of x .

(a) (i) State **one** control variable for this investigation.

(1)

(ii) Explain why it is necessary to control this variable.

(2)



(b) The student recorded the following data to plot a graph of θ against x .

$\theta / ^\circ$	x / cm
10	35.8
20.5	592
31	61

Criticise the recording of the data.

(3)

.....

.....

.....

.....

.....

.....

(c) The student wrote a laboratory report about her investigation.

She reported that the most significant source of error was being unable to judge the exact point where the ball landed. This was because the ball moved too quickly.

Explain **one** modification she could make to the apparatus to reduce this error.

You should include additional apparatus.

(2)

.....

.....

.....

.....

(Total for Question 2 = 8 marks)



3 A student determined the speed of ultrasound in air using the apparatus shown.

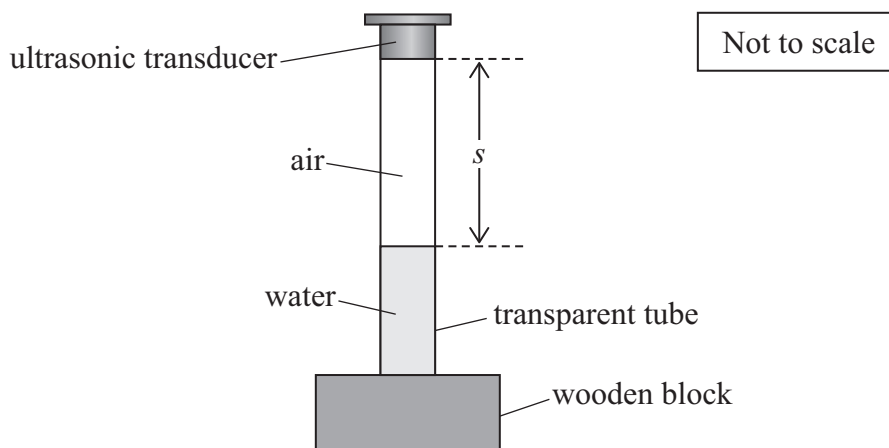

(a) The student added water to the transparent tube to change the length s of the air column.

Describe a method to determine a single value of s as accurately as possible, using a metre rule.

Your method may include additional apparatus.

(3)

.....

.....

.....

.....

.....

.....

DO NOT WRITE IN THIS AREA

DO NOT WRITE IN THIS AREA

DO NOT WRITE IN THIS AREA



(b) The ultrasonic transducer emitted pulses of ultrasound.

The emitted pulses were reflected at the water surface and then detected when they returned to the ultrasonic transducer.

The student connected an oscilloscope to the transducer, to determine the time between an emitted pulse and the reflected pulse.

The oscilloscope screen is shown below.

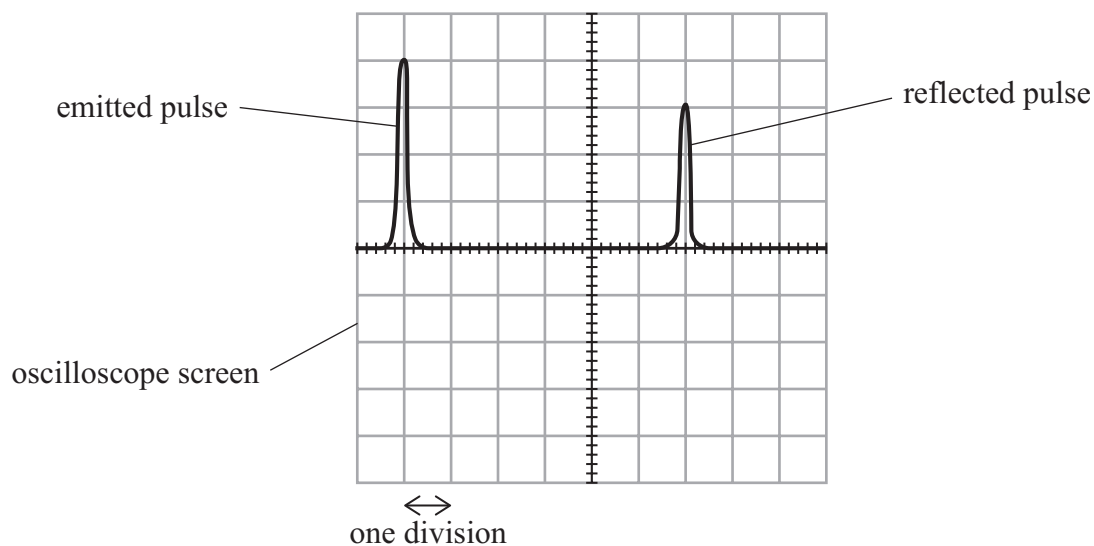

The horizontal axis represents time.

The time scale was set to 0.5 ms per division.

Show that, for this example, the speed v of ultrasound in air was about 330 m s^{-1} .

length of air column $s = 49.7 \text{ cm}$

(4)



(c) The student varied s and determined corresponding values for v . He recorded the following values.

v / ms^{-1}	335	347	339	342
----------------------	-----	-----	-----	-----

(i) Determine the mean value of v .

(2)

Mean value of $v =$

(ii) Determine the percentage uncertainty in the mean value of v .

(2)

Percentage uncertainty =

(d) The student modified the apparatus to determine the speed of sound in water.

He determined the speed of sound in water to be 1444ms^{-1} with a 4% uncertainty.

The accepted value for the speed of sound in water is 1481ms^{-1} .

Deduce whether the student's value for the speed of sound in water is consistent with the accepted value.

Your answer should include a calculation.

(2)

(Total for Question 3 = 13 marks)



DO NOT WRITE IN THIS AREA

DO NOT WRITE IN THIS AREA

DO NOT WRITE IN THIS AREA

BLANK PAGE



- 4 A student made measurements on a length of metal wire.
- (a) The student used a micrometer screw gauge to measure the diameter d of the wire.
- (i) The student recorded a single measurement of d as 0.27 mm.

Determine the percentage uncertainty in this measurement.

(2)

.....

.....

.....

Percentage uncertainty =

- (ii) The student repeated the measurement of d at different positions and orientations and calculated the mean.

Explain another technique she should use to determine an accurate value for d .

(2)

.....

.....

.....

.....



- (b) The student formed the wire into a loop. She used the circuit below to determine the resistance between two points, X and Y, on the loop.

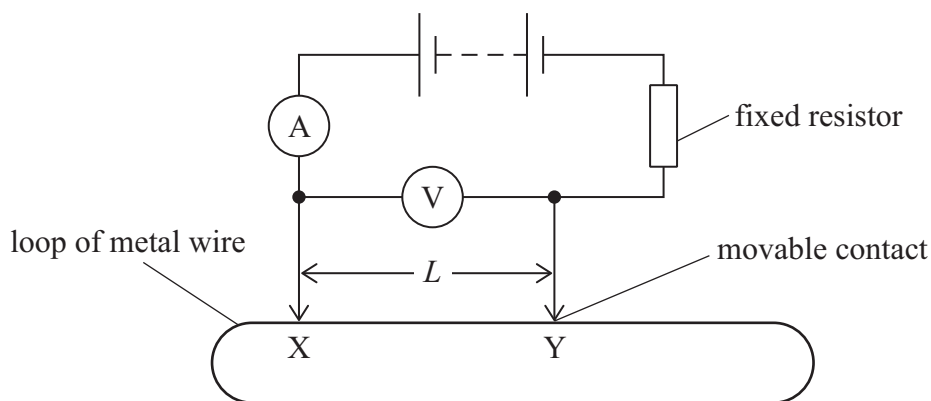

Explain why the fixed resistor is included in the circuit.

(2)

- (c) Using the circuit in (b), the student investigated how the resistance R between the points X and Y varied with the length L .

The relationship between R and L is

$$\frac{R}{L} = -kL + \frac{\rho}{A}$$

where

k is a constant

ρ is the resistivity of the metal

A is the cross-sectional area of the wire.

- (i) Explain how a graph of $\frac{R}{L}$ against L can be used to determine the value of ρ .

(2)



(ii) The student recorded the following data.

L / m	I / A	V / V	$\frac{R}{L}$
0.100	0.720	1.40	
0.200	0.390	1.39	
0.300	0.290	1.42	
0.400	0.250	1.48	
0.500	0.220	1.47	
0.600	0.210	1.47	

Complete the table with the corresponding values of $\frac{R}{L}$ (2)

(iii) Plot a graph of $\frac{R}{L}$ on the y -axis against L on the x -axis on the grid opposite. (5)

(iv) Determine the value of k from the graph. (3)

.....

.....

.....

.....

$k =$



DO NOT WRITE IN THIS AREA

DO NOT WRITE IN THIS AREA

DO NOT WRITE IN THIS AREA

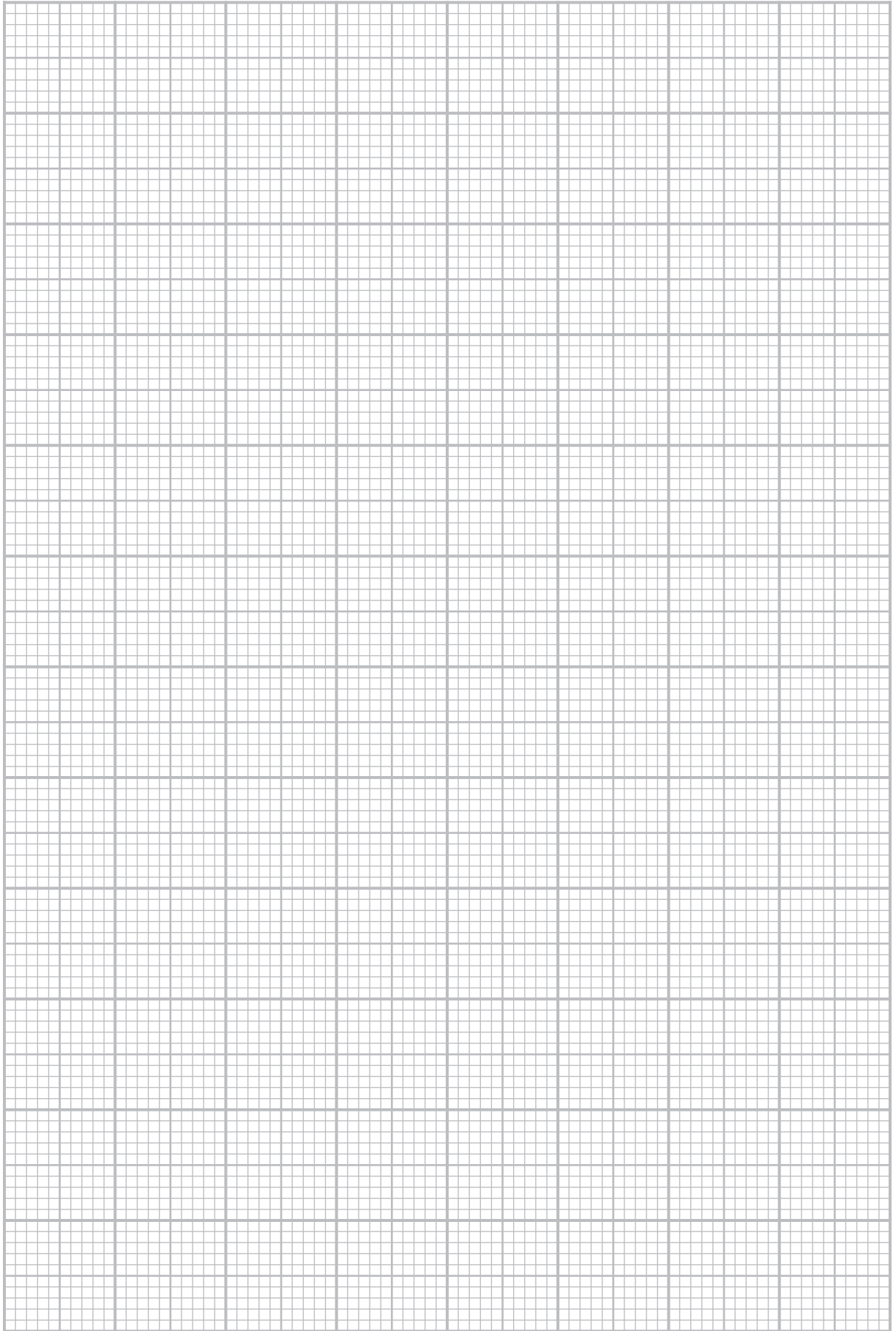

P 7 5 8 0 9 A 0 1 3 2 0

(v) Determine the value of ρ from the graph.

$$d = 0.27 \text{ mm}$$

(3)

$$\rho = \dots\dots\dots$$

(Total for Question 4 = 21 marks)

TOTAL FOR PAPER = 50 MARKS

DO NOT WRITE IN THIS AREA

DO NOT WRITE IN THIS AREA

DO NOT WRITE IN THIS AREA



List of data, formulae and relationships

Acceleration of free fall	$g = 9.81 \text{ m s}^{-2}$	(close to Earth's surface)
Electron charge	$e = -1.60 \times 10^{-19} \text{ C}$	
Electron mass	$m_e = 9.11 \times 10^{-31} \text{ kg}$	
Electronvolt	$1 \text{ eV} = 1.60 \times 10^{-19} \text{ J}$	
Gravitational field strength	$g = 9.81 \text{ N kg}^{-1}$	(close to Earth's surface)
Planck constant	$h = 6.63 \times 10^{-34} \text{ J s}$	
Speed of light in a vacuum	$c = 3.00 \times 10^8 \text{ m s}^{-1}$	

Unit 1

Mechanics

Kinematic equations of motion

$$s = \frac{(u + v)t}{2}$$

$$v = u + at$$

$$s = ut + \frac{1}{2}at^2$$

$$v^2 = u^2 + 2as$$

Forces

$$\Sigma F = ma$$

$$g = \frac{F}{m}$$

$$W = mg$$

Momentum

$$p = mv$$

Moment of force

$$\text{moment} = Fx$$

Work and energy

$$\Delta W = F\Delta s$$

$$E_k = \frac{1}{2}mv^2$$

Power

$$\Delta E_{\text{grav}} = mg\Delta h$$

$$P = \frac{E}{t}$$

$$P = \frac{W}{t}$$



Efficiency

$$\text{efficiency} = \frac{\text{useful energy output}}{\text{total energy input}}$$

$$\text{efficiency} = \frac{\text{useful power output}}{\text{total power input}}$$

Materials

Density

$$\rho = \frac{m}{V}$$

Stokes' law

$$F = 6\pi\eta rv$$

Hooke's law

$$\Delta F = k\Delta x$$

Elastic strain energy

$$\Delta E_{\text{el}} = \frac{1}{2}F\Delta x$$

Young modulus

$$E = \frac{\sigma}{\varepsilon} \text{ where}$$

$$\text{Stress } \sigma = \frac{F}{A}$$

$$\text{Strain } \varepsilon = \frac{\Delta x}{x}$$

DO NOT WRITE IN THIS AREA

DO NOT WRITE IN THIS AREA

DO NOT WRITE IN THIS AREA



Unit 2

Waves

Wave speed	$v = f\lambda$
Speed of a transverse wave on a string	$v = \sqrt{\frac{T}{\mu}}$
Intensity of radiation	$I = \frac{P}{A}$
Refractive index	$n_1 \sin \theta_1 = n_2 \sin \theta_2$ $n = \frac{c}{v}$
Critical angle	$\sin C = \frac{1}{n}$
Diffraction grating	$n\lambda = d \sin \theta$

Electricity

Potential difference	$V = \frac{W}{Q}$
Resistance	$R = \frac{V}{I}$
Electrical power, energy	$P = VI$ $P = I^2R$ $P = \frac{V^2}{R}$ $W = VIt$
Resistivity	$R = \frac{\rho l}{A}$
Current	$I = \frac{\Delta Q}{\Delta t}$ $I = nqvA$
Resistors in series	$R = R_1 + R_2 + R_3$
Resistors in parallel	$\frac{1}{R} = \frac{1}{R_1} + \frac{1}{R_2} + \frac{1}{R_3}$

Particle nature of light

Photon model	$E = hf$
Einstein's photoelectric equation	$hf = \phi + \frac{1}{2}mv_{\max}^2$
de Broglie wavelength	$\lambda = \frac{h}{p}$

DO NOT WRITE IN THIS AREA

DO NOT WRITE IN THIS AREA

DO NOT WRITE IN THIS AREA



DO NOT WRITE IN THIS AREA

DO NOT WRITE IN THIS AREA

DO NOT WRITE IN THIS AREA

BLANK PAGE



DO NOT WRITE IN THIS AREA

DO NOT WRITE IN THIS AREA

DO NOT WRITE IN THIS AREA

BLANK PAGE



DO NOT WRITE IN THIS AREA

DO NOT WRITE IN THIS AREA

DO NOT WRITE IN THIS AREA

BLANK PAGE

