

Write your name here

Surname

Other names

**Pearson Edexcel**  
**International**  
**Advanced Level**

Centre Number

--	--	--	--	--	--

Candidate Number

--	--	--	--	--

# Physics

**Advanced Subsidiary**  
**Unit 2: Physics at Work**

Thursday 8 June 2017 – Afternoon  
**Time: 1 hour 30 minutes**

Paper Reference

**WPH02/01**

**You must have:**

Ruler

Total Marks

## Instructions

- Use **black** ink or ball-point pen.
- **Fill in the boxes** at the top of this page with your name, centre number and candidate number.
- Answer **all** questions.
- Answer the questions in the spaces provided  
– *there may be more space than you need.*

## Information

- The total mark for this paper is 80.
- The marks for **each** question are shown in brackets  
– *use this as a guide as to how much time to spend on each question.*
- Questions labelled with an **asterisk** (\*) are ones where the quality of your written communication will be assessed  
– *you should take particular care with your spelling, punctuation and grammar, as well as the clarity of expression, on these questions.*
- The list of data, formulae and relationships is printed at the end of this booklet.
- Candidates may use a scientific calculator.

## Advice

- Read each question carefully before you start to answer it.
- Try to answer every question.
- Check your answers if you have time at the end.

Turn over ►

P48424A

©2017 Pearson Education Ltd.

1/1/1/1/



Pearson

## SECTION A

Answer ALL questions.

For questions 1–10, in Section A, select one answer from A to D and put a cross in the box .  
If you change your mind, put a line through the box  and then  
mark your new answer with a cross .

1 Which of the following is an SI base unit?

- A ampere
- B coulomb
- C joule
- D volt

(Total for Question 1 = 1 mark)

2 The current in a wire is 25 mA.

Calculate the total charge that passes a point in the wire in 200 s.

- A  $1.25 \times 10^{-4} \text{ C}$
- B  $1.25 \times 10^{-1} \text{ C}$
- C 5.00 C
- D  $5.00 \times 10^3 \text{ C}$

(Total for Question 2 = 1 mark)

DO NOT WRITE IN THIS AREA

DO NOT WRITE IN THIS AREA

DO NOT WRITE IN THIS AREA



3 The current-potential difference graph for an electrical component is shown.

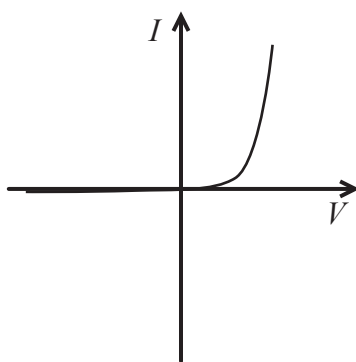

Which of the following is the electrical component?

- A diode
- B filament lamp
- C light dependent resistor
- D thermistor

(Total for Question 3 = 1 mark)

4 Which of the following is a possible unit for radiation flux?

- A  $\text{J m}^{-2}$
- B  $\text{J s}^{-1}$
- C  $\text{J s m}^{-2}$
- D  $\text{J s}^{-1} \text{m}^{-2}$

(Total for Question 4 = 1 mark)

5 A source of sound moves at a constant speed towards a stationary observer. The frequency of the observed sound wave differs from the frequency of the emitted sound wave.

The frequency of the observed sound wave is

- A higher because the speed of the observed wave is higher.
- B higher because the wavefronts are compressed.
- C lower because the speed of the observed wave is lower.
- D lower because the wavefronts are spread out.

(Total for Question 5 = 1 mark)



6 A motor has a power  $P$ . It is used to lift an object of mass  $m$  through a height  $h$  in time  $t$ .

Which of the following can be used to calculate the efficiency of the motor?

- A  $\frac{mgh}{Pt}$
- B  $\frac{Pt}{mgh}$
- C  $\frac{mghP}{t}$
- D  $\frac{t}{mghP}$

(Total for Question 6 = 1 mark)

7 Two waves, each with a wavelength of 2 cm, leave a single source in phase and follow the paths shown.

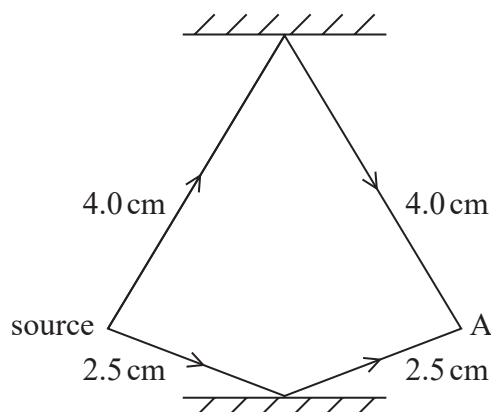

Which of the following is the phase difference, in radians, between the two waves as they meet at point A?

- A  $\frac{\pi}{4}$
- B  $\frac{\pi}{2}$
- C  $\pi$
- D  $\frac{3\pi}{2}$

(Total for Question 7 = 1 mark)



8 Which of the following quantities may be defined as the magnitude of the greatest distance of a point on a wave from the equilibrium position?

- A amplitude
- B displacement
- C phase
- D wavelength

(Total for Question 8 = 1 mark)

9 Light of varying frequency is incident on a metal electrode and the maximum kinetic energy of the electrons emitted is determined.

The maximum kinetic energy of the electrons varies with the frequency of the incident light as shown.

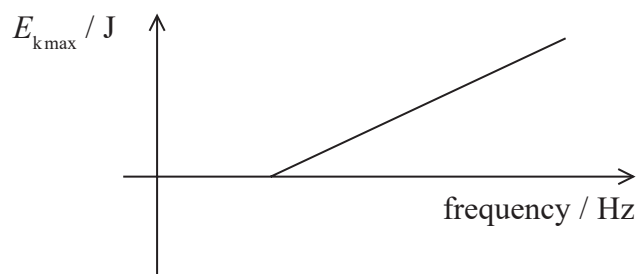

Which of the following is the numerical value of the gradient?

- A  $6.63 \times 10^{-34}$
- B  $9.11 \times 10^{-31}$
- C  $1.60 \times 10^{-19}$
- D  $3.00 \times 10^8$

(Total for Question 9 = 1 mark)



10 The circuit shows a potential divider.

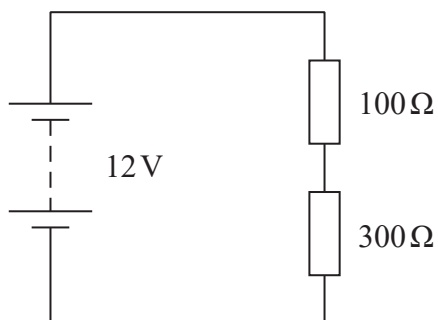

Which of the following is the value of the potential difference across the 100 Ω resistor?

- A 3 V
- B 4 V
- C 8 V
- D 9 V

(Total for Question 10 = 1 mark)

**TOTAL FOR SECTION A = 10 MARKS**

DO NOT WRITE IN THIS AREA

DO NOT WRITE IN THIS AREA

DO NOT WRITE IN THIS AREA



DO NOT WRITE IN THIS AREA

DO NOT WRITE IN THIS AREA

DO NOT WRITE IN THIS AREA

### SECTION B

Answer ALL questions in the spaces provided.

11 A student draws the pattern formed by a standing wave on a string.

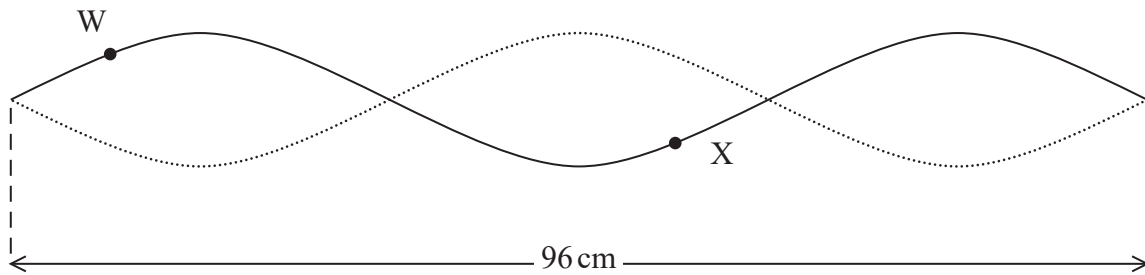

(a) Determine the wavelength of the wave.

(1)

Wavelength = .....

(b) W and X are points on the string.

State the phase difference between W and X.

(1)

(c) Describe how a standing wave is formed.

(3)

(Total for Question 11 = 5 marks)



12 Sensors can be fitted to the rear bumper of a car to help the driver reverse the car safely.

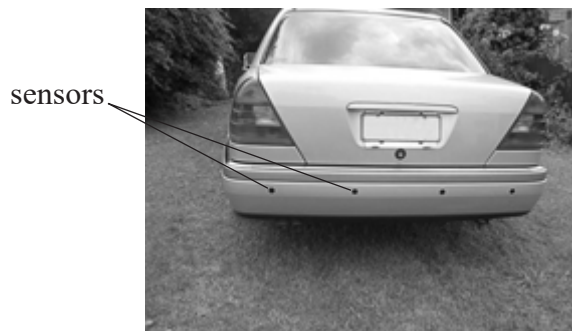

The sensors emit ultrasound pulses. Pulses that hit an object behind the car are reflected back to the sensors. The time taken for the reflected pulse to return is measured so that the distance to the object can be determined.

(a) State why it is necessary to emit the ultrasound in pulses. (1)

.....

.....

(b) A car manufacturer claims that the sensors are able to detect objects from a distance of 0.10 m from the car.

Calculate the maximum duration of each pulse.

speed of sound in air =  $340 \text{ m s}^{-1}$  (3)

.....

.....

.....

.....

.....

.....

Maximum duration = .....





(c) (i) Suggest why the sensors may not help the driver when reversing towards an ascending ramp.

(1)

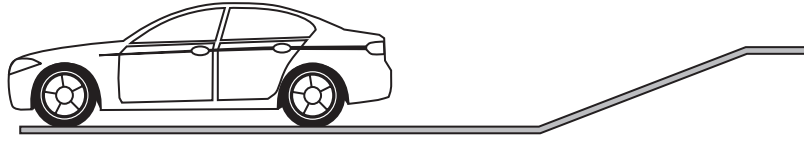

(ii) Suggest why the sensors may not help the driver when reversing towards a thin post.

(1)

**(Total for Question 12 = 6 marks)**



13 The diagram shows some of the energy levels for hydrogen.

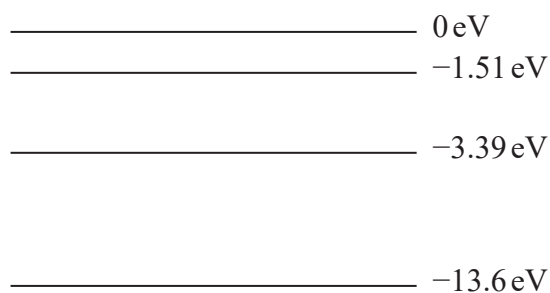

(a) State what is meant by the ground state of an atom. (1)

.....  
.....

(b) Identify the transition which would result in the emission of light of wavelength 660 nm. (4)

.....  
.....  
.....  
.....  
.....  
.....  
.....  
.....  
.....  
.....

Transition ..... eV to ..... eV



(c) A hydrogen atom is in its ground state. A photon with frequency  $5.4 \times 10^{15}$  Hz is absorbed and the atom becomes ionised.

Calculate the kinetic energy, in J, of the released electron.

(3)

.....

.....

.....

.....

.....

.....

Kinetic energy = ..... J

(d) When white light is passed through hydrogen gas, the emerging light produces an absorption spectrum.



Explain why certain wavelengths are missing from the emerging light.

(2)

.....

.....

.....

.....

**(Total for Question 13 = 10 marks)**



14 A student investigated the power that a battery can supply to a circuit.

The student connected a circuit to determine the electromotive force (e.m.f.)  $\mathcal{E}$  and internal resistance  $r$  of the battery. The load resistance  $R$  was varied. The corresponding readings of current  $I$  and terminal potential difference  $V$  were recorded from an ammeter and a voltmeter.

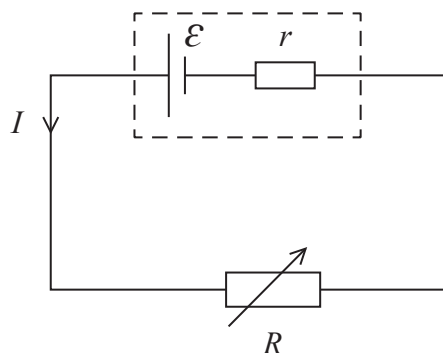

(a) State what is meant by the e.m.f.  $\mathcal{E}$  of the battery.

(2)

.....

.....

.....

(b) (i) Add to the circuit diagram to show the positions of the ammeter and the voltmeter.

(1)

(ii) Whilst taking the measurements, the student reduced the resistance of the variable resistor to zero.

Suggest why this could be a problem if the battery has a low internal resistance.

(1)

.....

.....



DO NOT WRITE IN THIS AREA

DO NOT WRITE IN THIS AREA

DO NOT WRITE IN THIS AREA

(c) The student plotted the results on a graph.

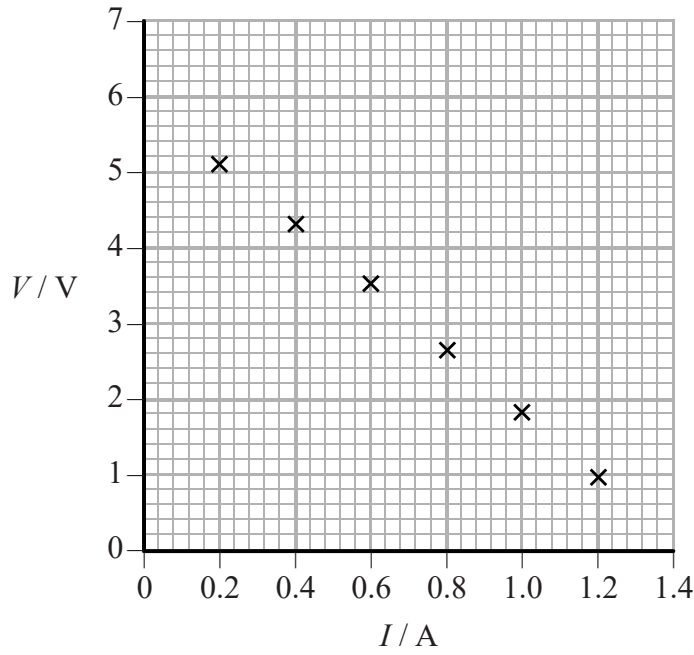

(i) Determine values for  $\mathcal{E}$  and  $r$ .

(4)

$\mathcal{E} = \dots\dots\dots$

$r = \dots\dots\dots$

(ii) The power transferred from the battery to the load resistance is a maximum when  $R = r$ .

Calculate the maximum power dissipated in  $R$ .

(3)

Maximum power =  $\dots\dots\dots$

(Total for Question 14 = 11 marks)



15 In a cinema, sound normally comes from a number of speakers placed at different positions around the room.

(a) Explain how sound travels through the air.

(3)

.....

.....

.....

.....

.....

.....

(b) What a listener hears depends on the position of the source of the sound.

The diagrams show a source of sound when it is placed

- in front of the listener
- to the left of the listener.

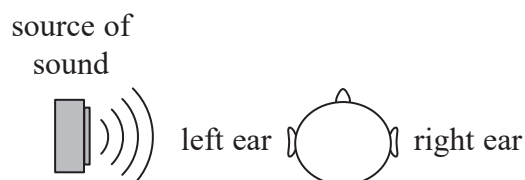
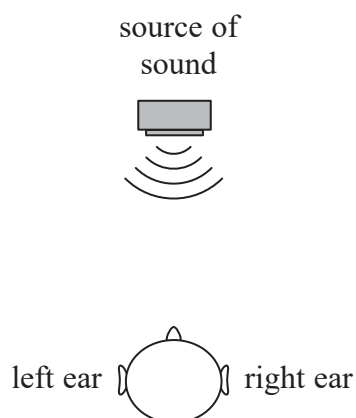

The sound waves from the source in front of the listener arrive at each ear at the same time.  
The sound waves from the source to the left of the listener arrive at the left ear first.  
The sound waves then reach the right ear by diffraction.

(i) Describe how the sound reaches the right ear by diffraction.

(2)

.....

.....

.....

.....





16 Tungsten is a metal commonly used for the filaments in light bulbs due to its high melting point.

- (a) The current in a filament is given by the equation  $I = nqvA$  where  $v$  is the drift velocity. Drift velocity is defined as

*the mean velocity of the free electrons in a current carrying conductor.*

- (i) Explain why drift velocity is defined as a mean velocity.

(2)

- (ii) The diagram shows a free electron in a tungsten filament. A potential difference is applied across the ends of the filament.

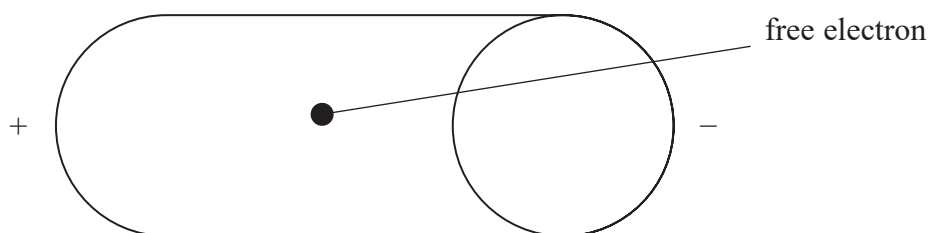

Draw on the diagram to show a possible path of the electron as it moves through the tungsten filament.

(2)





(b) In a 12 V light bulb, the tungsten filament has a length of 1.3 cm and cross-sectional area of  $7.9 \times 10^{-11} \text{ m}^2$ . When the bulb is first switched on, at room temperature, the current is 1.2 A.

(i) Calculate the resistivity of tungsten at room temperature.

(3)

.....

.....

.....

.....

.....

.....

Resistivity = .....

\*(ii) A short time after being switched on, the temperature of the filament has increased. At this temperature the resistivity of tungsten has also increased.

With reference to the lattice of the metal, explain why the resistivity has increased.

(4)

.....

.....

.....

.....

.....

.....

.....

.....

.....

.....

.....

(iii) Suggest why a tungsten filament is more likely to break when first switched on and not after it has been switched on for some time.

(1)

.....

.....

.....

(Total for Question 16 = 12 marks)



17 It is sometimes difficult for fishermen to see the fish due to glare, which is caused by the reflection of sunlight from the surface of the water. The use of polarising sunglasses can help to reduce the effect of glare, as shown in the photographs.

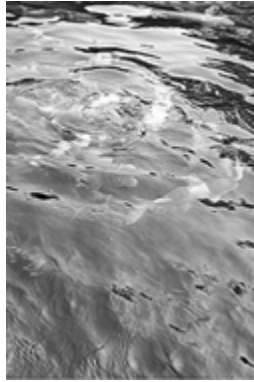

Without polarising sunglasses



With polarising sunglasses

(a) Describe what is meant by a polarised wave.

(2)

.....

.....

.....

.....

.....

.....

(b) Explain why the fish look darker when viewed through polarising sunglasses.

(2)

.....

.....

.....

.....

.....

.....



- (c) The diagrams show two polarising filters, A and B, which could be used in sunglasses. The arrows represent the plane of polarisation of light transmitted by the filter.

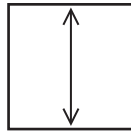

A

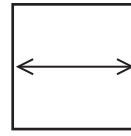

B

A fisherman is viewing fish, that are under the water, through polarising sunglasses. Light reflected from the surface of the water is partially polarised in a plane parallel to the surface of the water.

Explain which filter, A or B, the fisherman should have in the sunglasses in order to see the fish clearly.

(2)

---

(Total for Question 17 = 6 marks)

---



18 Diamonds are widely used in jewellery due to their ability to sparkle. Sparkling is caused by reflections of light inside the diamond.

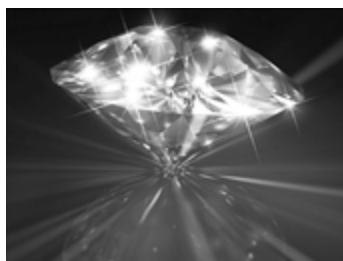

When used in jewellery, diamonds are cut to an optimum shape.

(a) The diagram shows the path of one ray of light as it passes through a cut diamond.

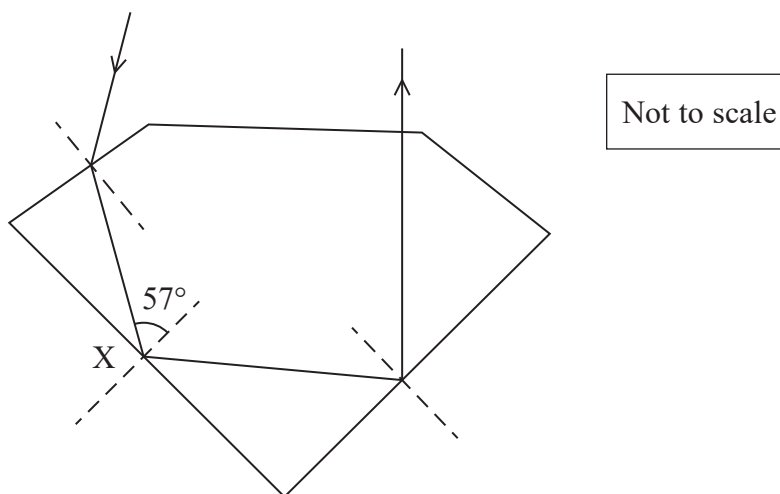

Explain the path taken by the ray of light when it is incident at the diamond-air interface at X. Your answer should include a calculation.

refractive index of diamond = 2.4

(4)

.....

.....

.....

.....

.....

.....

.....

.....

.....



DO NOT WRITE IN THIS AREA

DO NOT WRITE IN THIS AREA

DO NOT WRITE IN THIS AREA

(b) Zircon is a popular, cheaper alternative to diamond.

refractive index of diamond = 2.4

refractive index of zircon = 2.0

(i) Explain how a higher refractive index causes diamond to sparkle more than zircon.

(3)

.....

.....

.....

.....

.....

.....





## List of data, formulae and relationships

Acceleration of free fall	$g = 9.81 \text{ m s}^{-2}$	(close to Earth's surface)
Electron charge	$e = -1.60 \times 10^{-19} \text{ C}$	
Electron mass	$m_e = 9.11 \times 10^{-31} \text{ kg}$	
Electronvolt	$1 \text{ eV} = 1.60 \times 10^{-19} \text{ J}$	
Gravitational field strength	$g = 9.81 \text{ N kg}^{-1}$	(close to Earth's surface)
Planck constant	$h = 6.63 \times 10^{-34} \text{ J s}$	
Speed of light in a vacuum	$c = 3.00 \times 10^8 \text{ m s}^{-1}$	

### Unit 1

#### Mechanics

Kinematic equations of motion	$v = u + at$ $s = ut + \frac{1}{2}at^2$ $v^2 = u^2 + 2as$
-------------------------------	---

Forces	$\Sigma F = ma$ $g = F/m$ $W = mg$
--------	------------------------------------

Work and energy	$\Delta W = F\Delta s$ $E_k = \frac{1}{2}mv^2$ $\Delta E_{\text{grav}} = mg\Delta h$
-----------------	--

#### Materials

Stokes' law	$F = 6\pi\eta rv$
-------------	-------------------

Hooke's law	$F = k\Delta x$
-------------	-----------------

Density	$\rho = m/V$
---------	--------------

Pressure	$p = F/A$
----------	-----------

Young modulus	$E = \sigma/\epsilon$ where Stress $\sigma = F/A$ Strain $\epsilon = \Delta x/x$
---------------	--

Elastic strain energy	$E_{\text{el}} = \frac{1}{2}F\Delta x$
-----------------------	--

DO NOT WRITE IN THIS AREA

DO NOT WRITE IN THIS AREA

DO NOT WRITE IN THIS AREA



**Unit 2***Waves*Wave speed  $v = f\lambda$ Refractive index  ${}_1\mu_2 = \sin i / \sin r = v_1 / v_2$ *Electricity*Potential difference  $V = W/Q$ Resistance  $R = V/I$ 

Electrical power, energy and efficiency

$$P = VI$$

$$P = I^2R$$

$$P = V^2/R$$

$$W = VI t$$

$$\% \text{ efficiency} = \frac{\text{useful energy output}}{\text{total energy input}} \times 100$$

$$\% \text{ efficiency} = \frac{\text{useful power output}}{\text{total power input}} \times 100$$

Resistivity  $R = \rho l/A$ 

Current

$$I = \Delta Q / \Delta t$$

$$I = nqvA$$
Resistors in series  $R = R_1 + R_2 + R_3$ Resistors in parallel  $\frac{1}{R} = \frac{1}{R_1} + \frac{1}{R_2} + \frac{1}{R_3}$ *Quantum physics*Photon model  $E = hf$ Einstein's photoelectric equation  $hf = \phi + \frac{1}{2}mv_{\max}^2$ 